

DOC023.52.00079.Jun05

EVITA® PH

User Manual



LANGE 

The Lange logo icon is a red square containing a white stylized "C" or circular symbol.

© HACH LANGE GmbH, 2005. All rights reserved. Printed in Germany



Contents

Introduction	2	Programming USC 5000/6000/7000	19	Troubleshooting	42
Mechanical Installation	4	Keypad and display layout	19	Error system	42
Transmitter	4	Factory settings	20	Troubleshooting guide -	
Assembly	6	Menu structure	21	PH 4100 (REDOX) stand alone transmitter.....	44
Pipe-mounting	7	USC 7000 multidrop system.....	24	Troubleshooting guide -	
Mounting of PH 1100 sensor and		Setting of transmitter's current output		PH 4100 / REDOX 4100 transmitter.....	45
REDOX 1100 sensor	8	and temperature unit	25	Troubleshooting guide -	
USC 5000/6000/7000.....	9	USC 5000/6000 current output settings	26	signal converter	46
USC 6000/7000 19" version	10	USC 7000 current output settings	27	Technical Data	49
Optional add-on module USC 6000/7000	11	USC 6000 relay output settings.....	28	PH 4100 / REDOX 4100 transmitter.....	49
Optional add-on module USC 6000/7000		USC 7000 relay output settings.....	29	PH 1100 sensor	50
19" version.....	12	Calibration (PH only)	30	REDOX 1100 sensor	50
Electrical Installation	13	Maintenance	34	Universal Signal Converter	
PH 4100 / REDOX 4100		System information	36	USC 5000/6000/7000	51
stand alone transmitter.....	13	Transmitter information.....	36	HART®	53
USC 5000/6000 and PH 4100 / REDOX 4100		USC information	37	Warranty, liability and complaints	54
point to point.....	15	Other Menus	38	Contacts	55
USC 7000 and PH 4100 / REDOX 4100	16	Operator menu setup	38		
Initial Start Up	17	Advanced settings	39		
PH 4100 / REDOX 4100		Service mode	40		
stand alone transmitter	17	Reset mode	41		
System with USC 5000/6000/7000	18	Send command	41		

Introduction



PH 1100 sensor



PH 4100 / REDOX 4100 transmitter



REDOX 1100 sensor

EVITA® PH / REDOX transmitters are used for measuring pH and redox in water.

EVITA® PH consists of a PH 1100 sensor, a PH 4100 transmitter and a USC Universal Signal Converter.

There are two types of the PH 1100 sensor – one with zero point 4.6 and one with zero point 7.0. The operating principle is identical for both versions.

There are three versions of the USC - a USC 5000 basic version, and a USC 6000 with added features, both point to point. A USC 7000 with HART® multidrop functionality enabling up to 15 transmitters on only two wires.

The PH 4100 / REDOX 4100 transmitter is very easy to install as electrode, fitting and amplifier are all in one unit. Due to the compact design, the EVITA® PH / REDOX transmitter is simply inserted in the measuring media or it is pipe mounted.

This manual covers the EVITA® PH and the EVITA® REDOX transmitter. Some of it covers the EVITA® PH transmitter only. The mechanical and electrical installation is the same for both transmitter types.



Documentation needs to be consulted.



The user shall be made aware of that, if the equipment is used in a manner not specified by the manufacturer, the protection provided by the equipment may be impaired.



USC 5000 IP 67 (NEMA 4X)



USC 6000/7000 IP 67 (NEMA 4X)



USC 6000/7000 19"



The EVITA® PH / REDOX system offers several advantages:

2-wire transmitter

- simple and fast installation

Easy maintenance

- simple automatic calibration in buffer solutions initiated by using the TILTCAL® or the ring switch
- pH and reference electrodes, temperature sensor and amplifier in one unit
- simple sensor replacement after app. 1-2 years

High reliability

- self-diagnostics
- electrode monitoring
- fault indication on transmitter current output

Flexible communication

- HART® communication as standard gives added features
 - setting of measuring range from a distance
 - display of pH level, redox potential, temperature, and specific event codes
- Option module can be fitted in the USC 6000/7000 without the need for tools



Mechanical Installation

Transmitter

Mounting on a handrail

The mounting bracket for PH 4100 / REDOX 4100 can be mounted directly on a handrail using the supplied pipe clamps. Retighten the pipe clamps after a few days use to ensure a tight mounting of the mounting bracket.

In case of strong sideways forces, the PVC pipe should be mounted with supporting wires. This takes up some of the sideways mechanical forces on the pipe and avoids cracking of the mounting bracket.

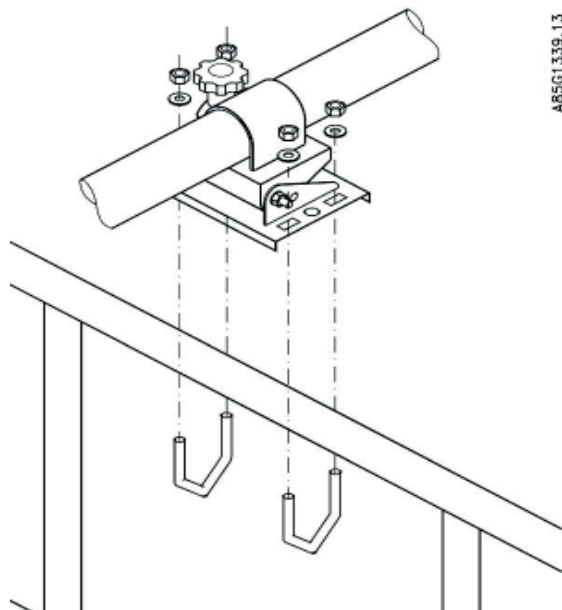
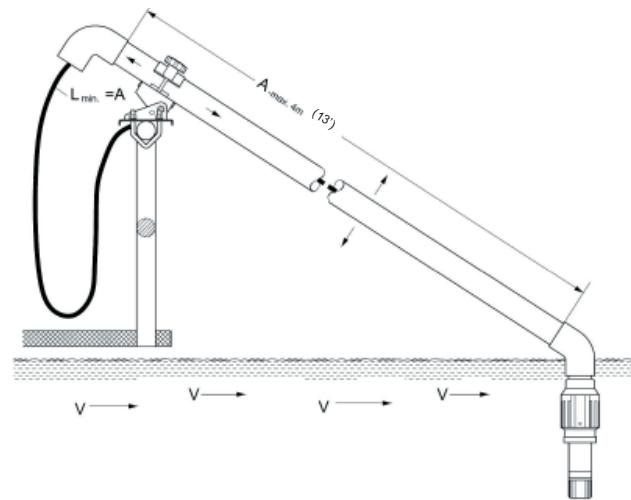

Fig. 1



$$v_{min} = 0.01 \text{ m/s (0.4"/sec)}$$

$$v_{max} = 3 \text{ m/s (9.8'/sec)}$$

Fig. 2

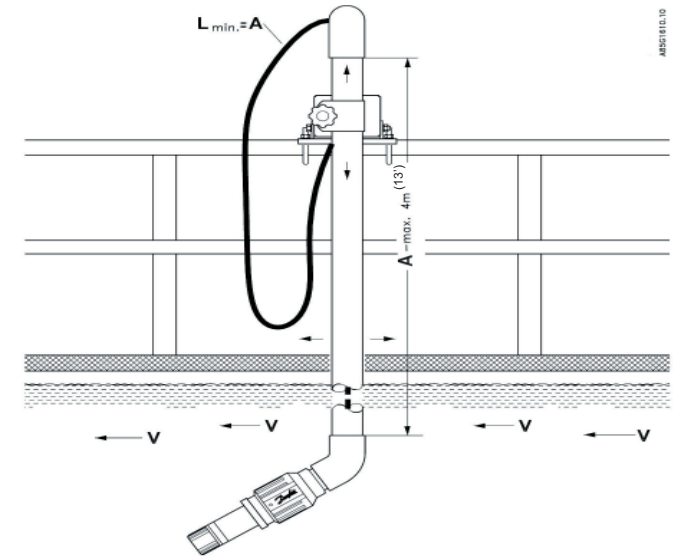

$$v_{min} = 0.01 \text{ m/s (0.4"/sec)}$$

$$v_{max} = 3 \text{ m/s (9.8'/sec)}$$

Fig. 3

Mounting on a concrete wall

The mounting bracket for the PH 4100 /REDOX 4100 transmitter can be mounted directly on to a concrete wall using 2 bolts AISI 316 (diameter max. 10 mm or 3/8 UN). The mounting bracket can be mounted either on the top or on the inside of the basin wall.

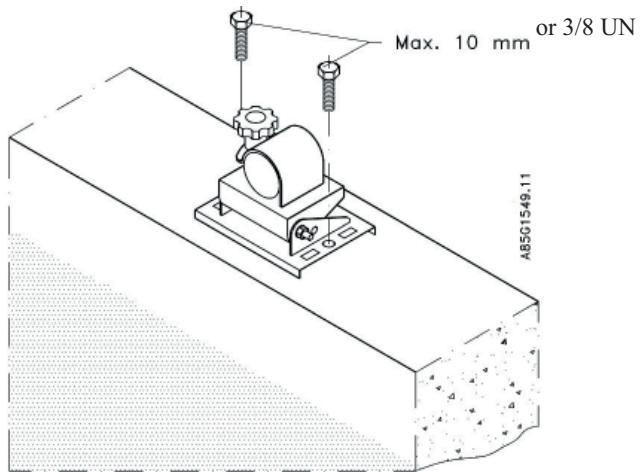

Fig. 4

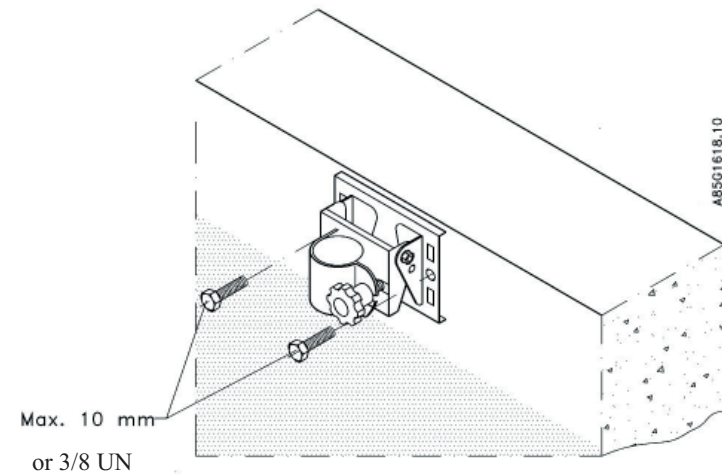

Fig. 5

Assembly

Important (PH only): If the calibration is to be performed by using the TILTCAL®, the ring switch must be demounted before assembling.

The protection cap must be removed and the PH1100 / REDOX 1100 sensor must be cleaned with water before use. The protection cap can be disposed as ordinary waste.

Mount the single parts as shown in fig. 6.

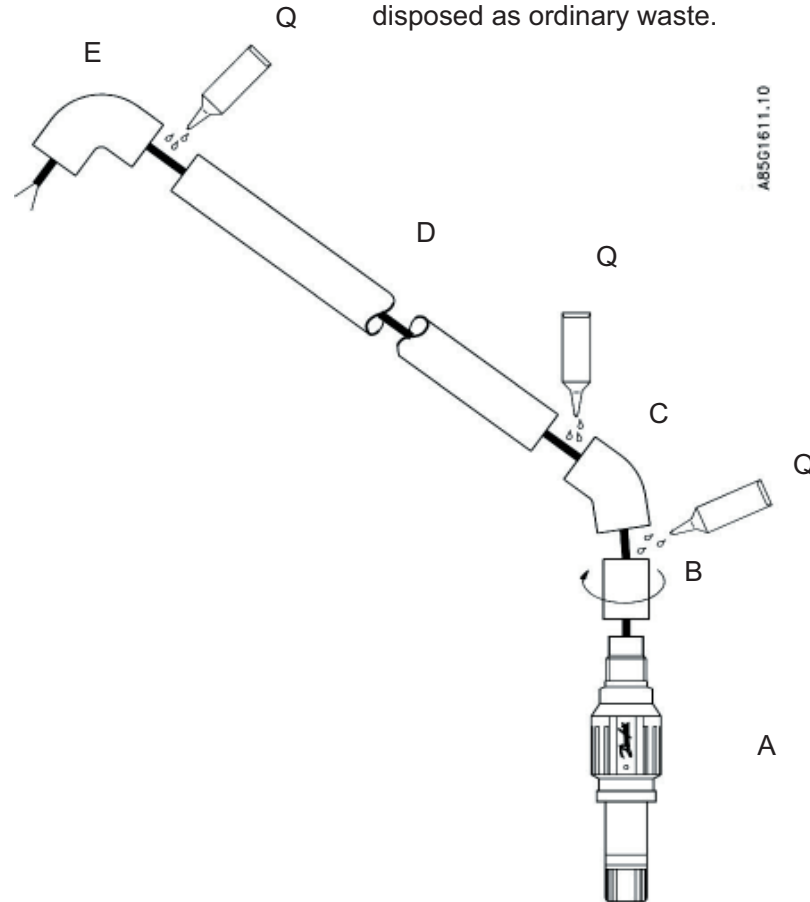

- A: PH 4100 /REDOX 4100; 1 1/4" pipe thread
- B: is supplied with transmitter
- C: 45° PVC or ABS elbow; inside diameter: 50 mm or 1 1/2"; supplied by customer
- D: PVC or ABS tube; 50 mm or 1 1/2"; supplied by customer
- E: 90° PVC or ABS elbow; inside diameter: 50 mm or 1 1/2"; supplied by customer
- Q: PVC or ABS adhesive; supplied by customer

Fig. 6

Pipe-mounting

The EVITA® PH 4100 /REDOX 4100 transmitter can also be pipe-mounted with a standard 2" plastic collar.

Warning: Do not remove the EVITA® PH 4100 / REDOX 4100 when the pipe is under pressure.



Pressure: Max. 5 bar (72.5 PSI)

Mounting of PH 1100 sensor and REDOX 1100 sensor

Mount the sensor on the transmitter as shown in fig. 7. Tighten thoroughly to ensure that the assembly is completely sealed.

The worn PH 1100 / REDOX 1100 sensor can be disposed as ordinary industrial waste.

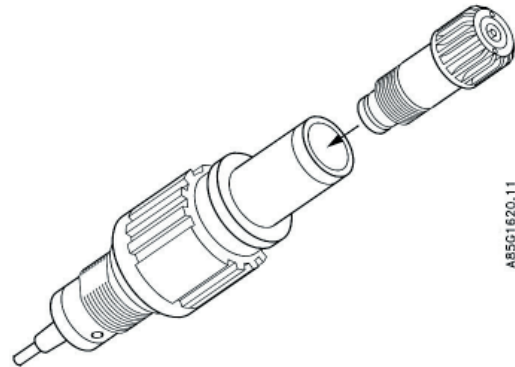

Fig. 7

USC 5000/6000/7000

Mounting on a handrail

Mount the bracket on a vertical or horizontal pipe using the two stainless steel hose clips.

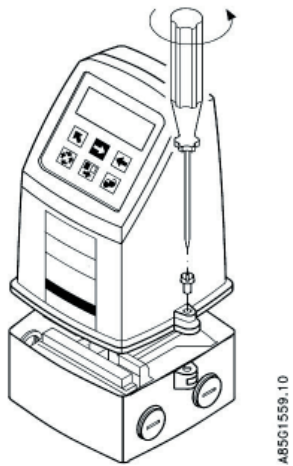

Fig. 8

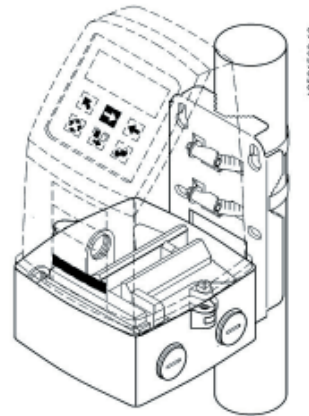

Fig. 9

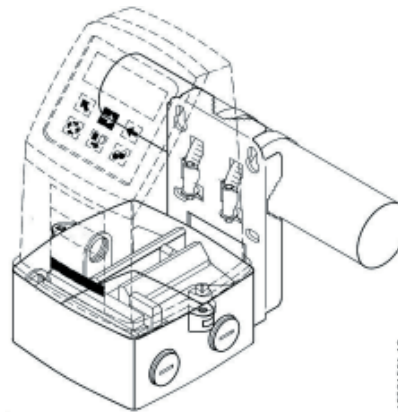

Fig. 10

Mounting on a concrete wall

Mount the bracket on a wall using four bolts (diameter max. 8 mm or 5/16 UN).

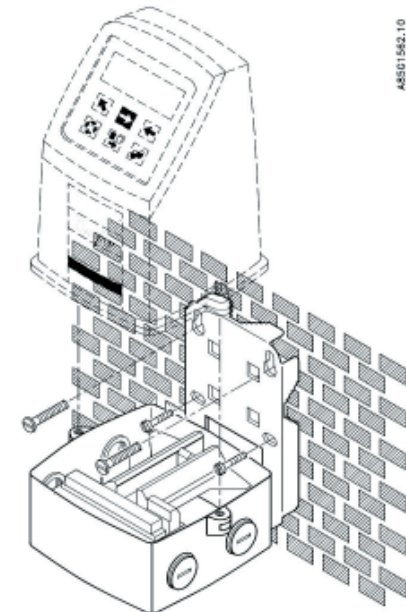

Fig. 11

USC 6000/7000 19" version

Mounting in panel

First mount the terminal board in the front panel IP 65 (NEMA 4X) enclosure, figs. 12 and 13, or the back of the panel bracket, fig. 14. Plug in the 19" USC 6000/7000 signal converter in the enclosure or bracket using the four small screws to tighten it.

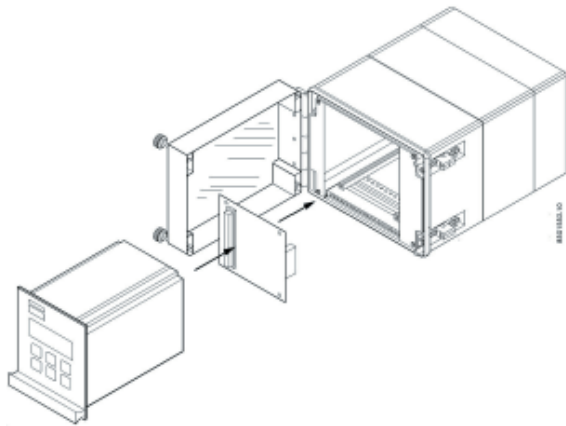

Fig. 12

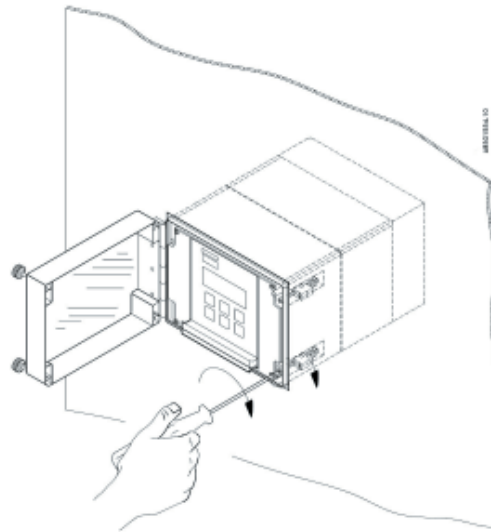

Fig. 13

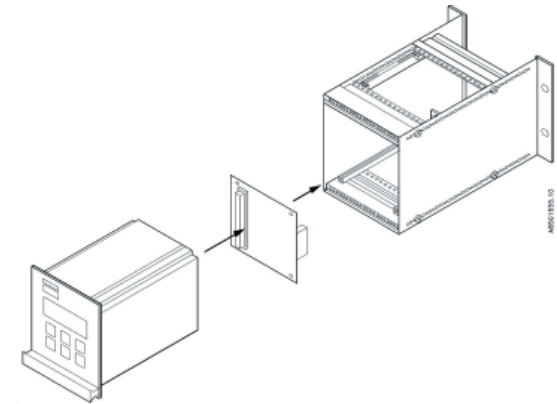

Fig. 14

Optional add-on module USC 6000/7000

Unpack the add-on module and locate it in the bottom of the signal converter as shown in fig. 15.

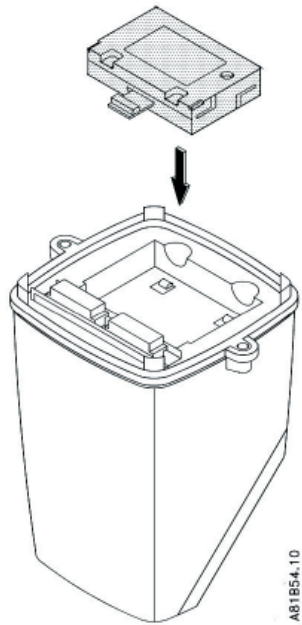

Fig. 15

Press the add-on module forward as far as possible. See fig. 16. Avoid touching the pc board and the sockets.

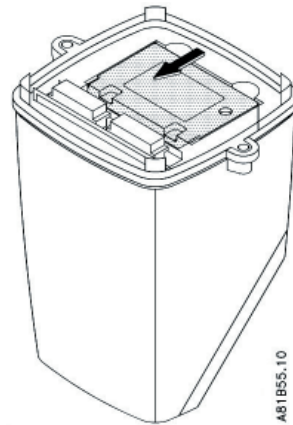

Fig. 16

The add-on module has now been installed and the signal converter is ready to be installed on the terminal box. The menus related to the optional add-on module will automatically become visible and electrical inputs and outputs are automatically established by power on.

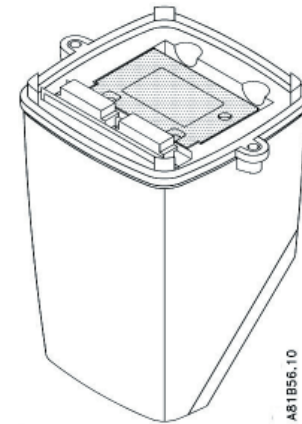

Fig. 17

Optional add-on module USC 6000/7000 19" version

Unpack the add-on module and locate it in the bottom of the signal converter as shown in fig. 18.

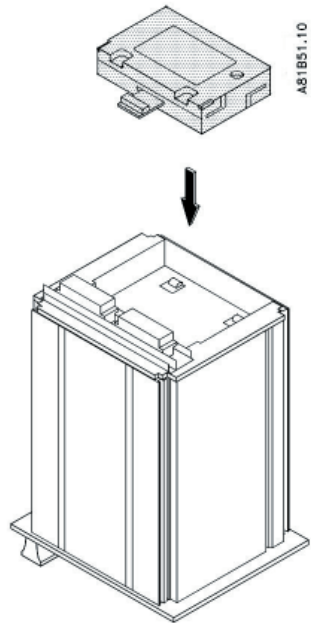

Fig. 18

Press the add-on module forward as far as possible. See fig. 19. Avoid touching the pc board and the sockets.

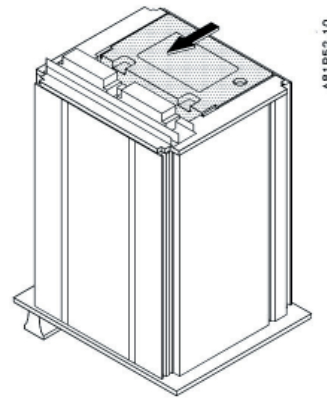

Fig. 19

The add-on module has now been installed and the signal converter is ready to be installed on the terminal box. The menus related to the optional add-on module will automatically become visible and electrical inputs and outputs are automatically established by power on.

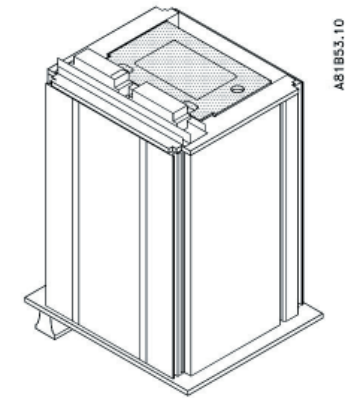

Fig. 20

Electrical Installation

PH 4100 / REDOX 4100 stand alone transmitter

The transmitter is connected using the two-wire, shielded cable. The two leads carry supply voltage, a 4-20 mA current signal and HART® communication.

If the cable is extended, the total length of the cable must not exceed 1000 m (3000'). Always use two-wire, shielded cable for the extension (min. 2 x 0.2 mm² (24 AWG)).

Examples of coupling to loop-powered display and PLC/SCADA system are shown in fig. 21, fig. 22 and fig. 23, respectively.

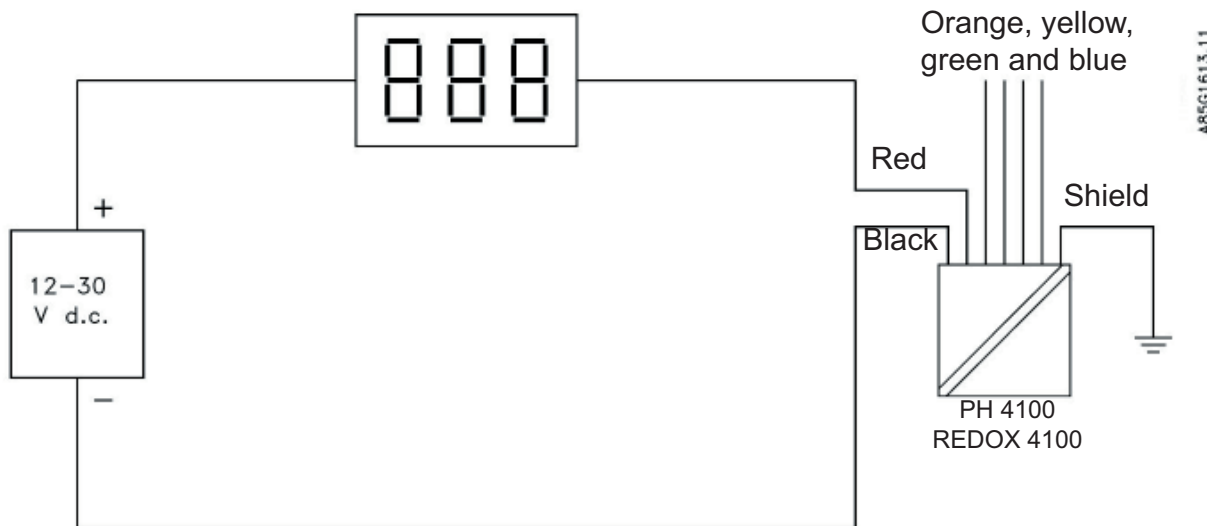

EVITA® PH / REDOX connected to loop-powered display.

Fig. 21

If the cable is shortened, 4 extra leads (orange, yellow, green and blue) will appear. These have been used for factory programming and are **not** for customer use.



A suitable power supply shall be considered in the end-use application. The power supply must be a Class 2 power source (limited circuit) according to the National Electrical Code (NEC) and provided double/reinforced insulation between mains and the 12-30 V d.c. supply for the pH transmitter.

If the cable is shortened, 4 extra leads (orange, yellow, green and blue) will appear. These have been used for factory programming and are **not** for customer use.

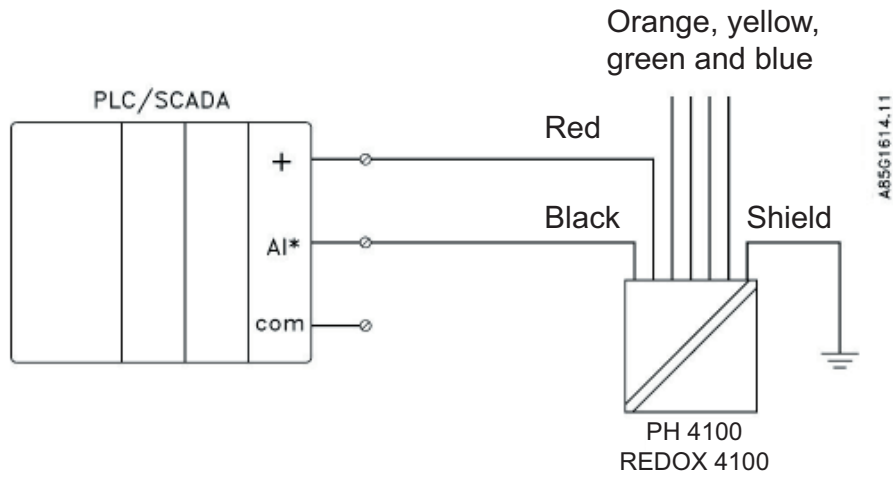

EVITA® PH / REDOX supplied from PLC/SCADA system.

Fig. 22

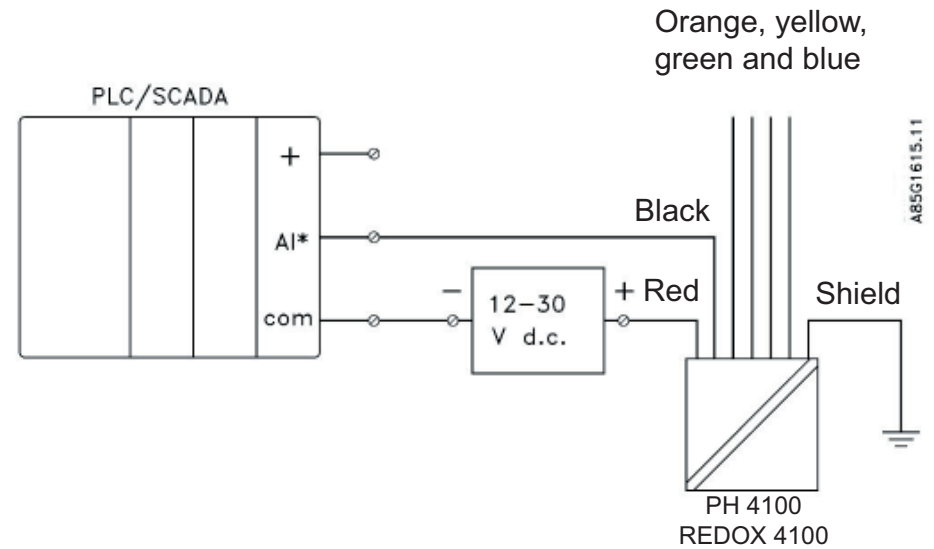

EVITA® PH / REDOX connected to a PLC/SCADA system with external power supply.

Fig. 23

USC 5000/6000 and PH 4100 / REDOX 4100 point to point

The transmitter is connected using the two-wire, shielded cable. The two leads carry supply voltage, a 4-20 mA current signal and HART® communication.

Depending on the USC version the power supply should be connected to terminals L, N and PE when using 110-240 V a.c., or to terminals 1 and 2 when using 24 V a.c./d.c., see fig. 24 and fig. 25.

If the cable is extended, the total length of the cable must not exceed 1000 m (3000'). Always use two-wire, shielded cable for the extension (min. 2 x 0.2 mm² (24 AWG)).

If the cable is shortened, 4 extra leads (orange, yellow, green and blue) will appear. These have been used for factory programming and are **not** for customer use.

On the USC signal converter it is possible to disable the function of the digital input (used for calibration control on the EVITA® INSITU 4100 transmitter).

Note: The digital input is available on both USC 5000, USC 6000 and USC 7000.

USC 5000/6000 - IP 67 version

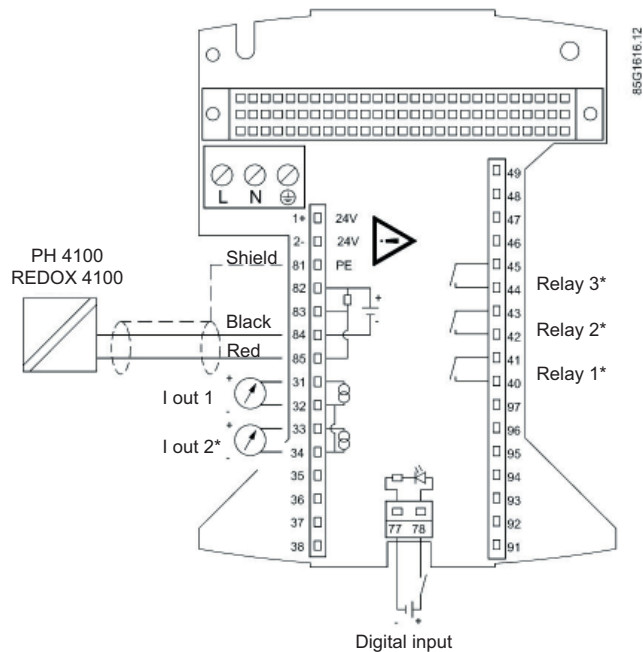

*Only USC 6000

Fig. 24

USC 6000 - 19" version

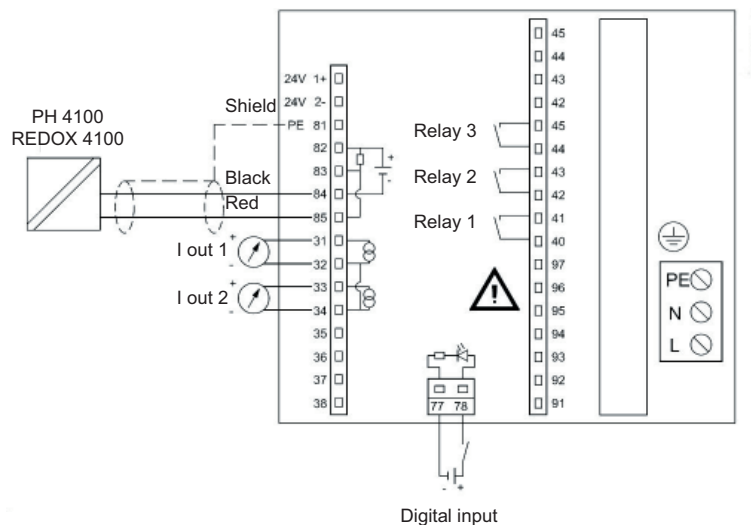

Fig. 24a

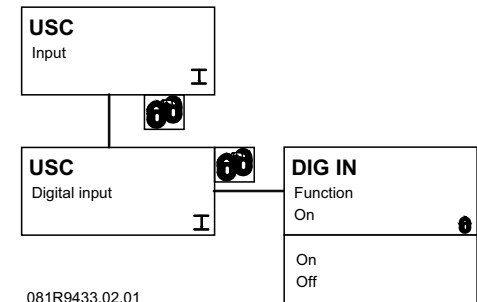

Fig. 25

USC 7000 and PH 4100 / REDOX 4100

The USC 7000 is able to communicate with up to 15 different EVITA® transmitters using HART® multidrop protocol on only two wires.

Each transmitter should be connected in parallel outside the USC connection box and only two wires with shield mounted on the terminals in the USC 7000.

If the cable is shortened, 4 extra leads (orange, yellow, green and blue) will appear. These have been used for factory programming and are **not** for customer use.

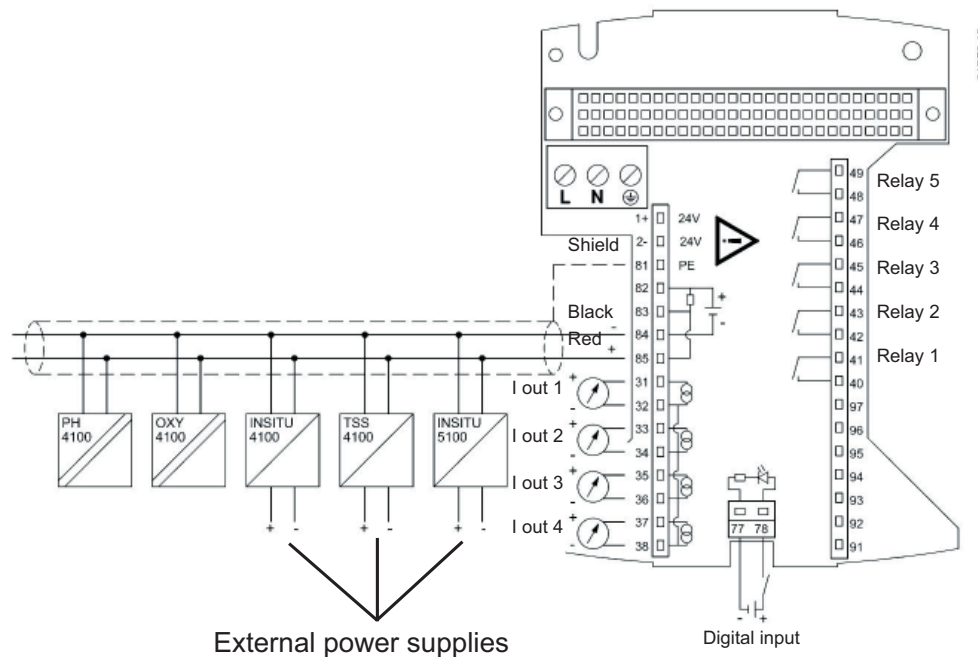

Fig. 26

External power supplies

Important: The below mentioned warnings concern both USC 5000, USC 6000 and USC 7000.

- ⚠ The HART communication terminals (84/85) and the Digital Input terminals (77/78) of the Signal Converter must not be connected to external voltage level above 30V d.c.
- ⚠ The Relay terminals (40-49) of the Signal Converter must not be connected to external voltage level exceeding 48V d.c., 30Vrms or 42Vpeak.
- ⚡ Protective conductor terminal. Required cable min. AWG16 or 1.5 mm² Cu.
- ⚠ Field wiring installation of the Signal Converter must be in accordance with the National Electrical Code.
- ⚠ Mains supply 100 to 240V a.c. from building installation (overvoltage category II). A switch or circuit-breaker (max. 15A) shall be included in the building installation. The switch/circuit-breaker shall comply with relevant requirements of IEC 947-1 and 947-3. It must be in close proximity to the equipment and within easy reach of the operator, and it shall be marked as the disconnecting device for the equipment.

Initial Start Up

PH 4100 / REDOX 4100 stand alone transmitter

1. Ensure that the protection cap is removed and that the PH 1100 / REDOX 1100 sensor has been cleaned with water.



2. Apply voltage to the transmitter. Place it in the medium.

3. After minimum 1 hour calibrate in accordance with the instructions in the "Calibration" section p. 30.

4. After calibration is completed, place the transmitter in the measuring media.

5. To ensure optimum accuracy, recalibrate the transmitter after 24 hours.

Item 3, 4 and 5 is for PH only.



Important: Immerse the transmitter quickly into the water to prevent the PH 1100 / REDOX 1100 sensor from drying out and becoming damaged.

System with USC 5000/6000/7000

1. Ensure that the protection cap is removed and that the PH 1100 / REDOX 1100 sensor has been cleaned with water.
2. Turn on the power to the signal converter USC 5000/6000/7000.
3. Place the transmitter in the medium.
4. Check factory settings, see p. 20. Change if necessary.
5. Calibrate in accordance with the instructions in the "Calibration" section, p. 30.
6. After calibration is completed, place the transmitter in the measuring media.
7. To ensure optimum accuracy, recalibrate the transmitter after 24 hours.



Important: Immerse the transmitter quickly into the water to prevent the PH 1100 / REDOX 1100 sensor from drying out and becoming damaged.

Item 5, 6 and 7 is for PH only.





Programming USC 5000/6000/7000

Keypad and display layout









Fig. 27



Various display symbols

-  Ready for change
-  Value locked
-  Access to submenu
-  Confirmation of choice



The keypad is used to set the EVITA® PH/REDOX and to step through the menus. The function of the keys are as follows:

TOP UP KEY (ESC)		This key (hold for 2 sec.) is used to switch between the operator menu and setup menu. A short press will cause a return to the overlying menu.
FORWARD KEY		This key is used to step forward through the menus in the setup menu.
BACKWARD KEY		This key is used to step backward through the menus.
CHANGE KEY		This key changes the settings or numerical values in the setup menu. In the operator menu it is used to step through the menus.
SELECT KEY		This key selects which digits to be changed.
LOCK/UNLOCK KEY (ENTER)		This key allows the operator to change settings and gives access to submenus.

IMPORTANT:

The USC starts up showing the menu “Language” in English. Press the  key until the wanted language appears in the display and press the  key. After the language is chosen, the USC will show “pH”/“Redox” in the operator menu (see p. 21).

The factory setting of the language can be re-established as follows:

- Switch off the power supply
- Press the  key and switch on the power supply
- Release the  key after 10 seconds

The language is now reset to English.

Factory settings

The EVITA® PH / REDOX system is supplied with the following factory settings:

Parameter		Factory settings	Options	Page
USC 5000/6000/7000	Current output 1 (System package 1 and 2)	0-14	pH: Range: min. 0; max. 14; Span: min. 2 Redox: Range: min. -1000 mV; max. +1000 mV; Span: min. 200 mV	26
	Current output 2 (System package 1)	0-40 °C	Range: min. -10°C (14°F) max. 70°C (158°F) Span: min. 1°C (1.8°F)	26
	Current outputs USC 5000/6000/7000	OFF	OFF ON	27
	Relays 1, 2 and 3 (USC 6000)	OFF	Alarm; Warming; Limit; Timer; OFF	28
	Relays 1, 2, 3, 4 and 5 (USC 7000)	OFF	Alarm; Warming; Limit; Timer; OFF	29
	Password	1000	1000-9999	23
PH 4100 / REDOX 4100	Current output	0-14	pH: Range: min. 0 max. 14 Span: min. 2 Redox: Range: min. -1000 mV max. +1000 mV Span: min. 200 mV	25
	Temperature unit	°C	°C; °F	25
	TILTCAL®	Enabled	Enabled; Disabled	39
	Current out put when not measuring	Hold	High; Low; Hold (last measured value); Normal	39
	Current output during error	Normal	High; Low; Normal	39
	Time constant	5 sec.	5 - 300 sec.	39

If factory settings are satisfactory, proceed to p. 30.

Menu structure

The menu of the signal converter is built up in two parts. An **operator menu** and a **setup menu**.

Operator menu

The operator menu is for daily use. After the language has been selected, the signal converter starts up in the operator menu showing the actual pH/ redox level.

The USC 5000/6000 is point-to-point installation while the USC 7000 is for a multidrop system. In fig. 28 menus marked with gray are only visible in the multidrop system. It is possible to hide some of the menus in the operator menu, see fig. 40, p. 38.

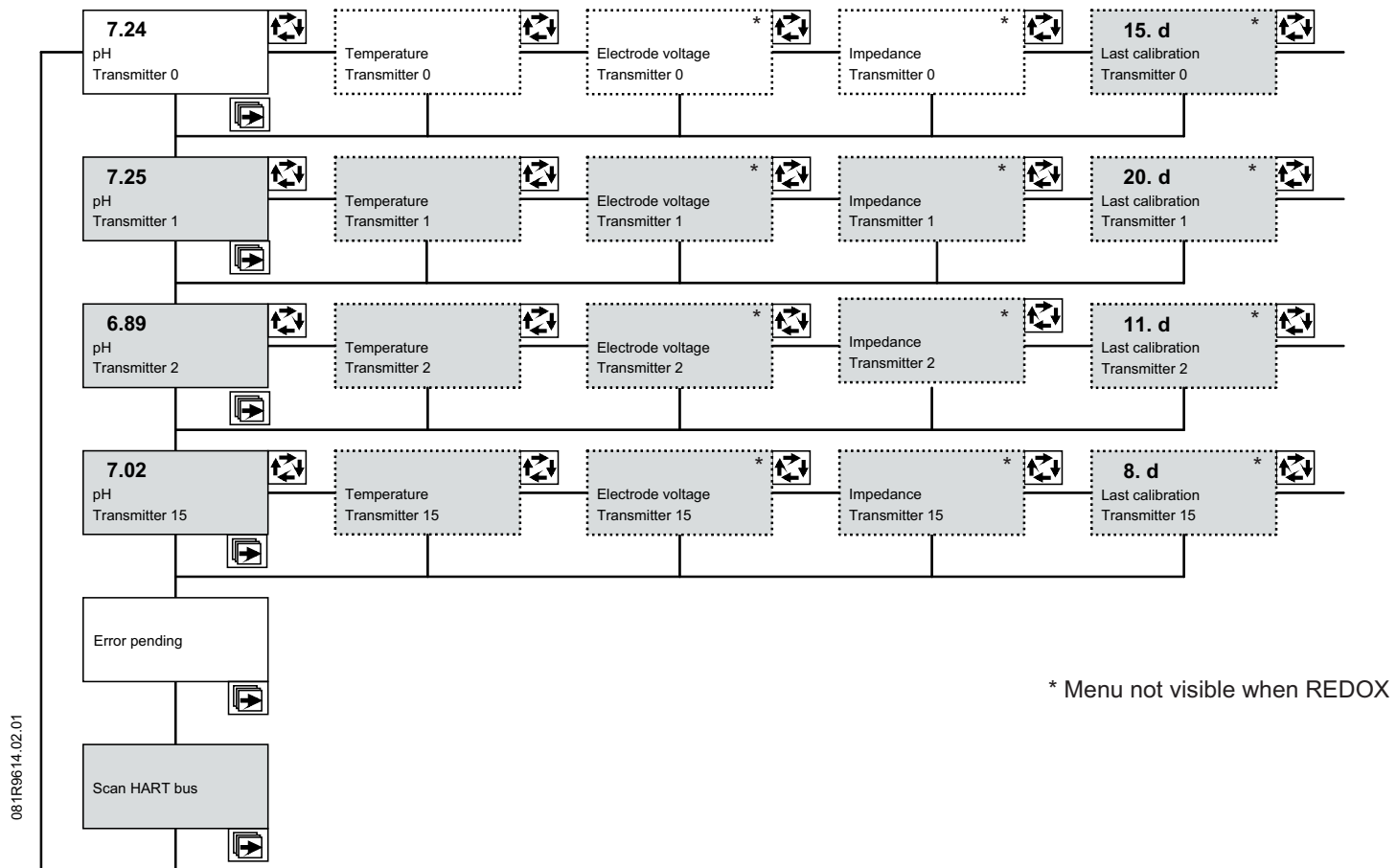



Fig. 28



Setup menu

The setup menu is shown in an overview diagram (fig. 29) that is shown on page 23.

The setup menu consists of two parts:



- USC setup menu - for USC settings
- Transmitter setup menu - for transmitter settings

The setup menu is for commissioning and service and for changing the settings. Access to the setup menu is gained by pressing the  key for 2 seconds. The setup menu will operate in two modes:

• **View mode** is a read only mode. The pre-selected settings can only be scanned. The view mode is accessed by pressing the  key for 2 seconds. Instead of keying in the password, press the  key.

• **Setup mode** is a read and write mode. The pre-selected settings can be scanned and changed. The setup menu is accessed by pressing the  key for 2 seconds and entering the password. The factory set password is 1000, but can be changed to any value between 1000 and 9999.

The factory setting of the password can be re-established as follows:

- Switch off the power supply
- Press the  key and switch on the power supply
- Release the  key after 10 seconds

The password is now reset to 1000.

Fig. 29

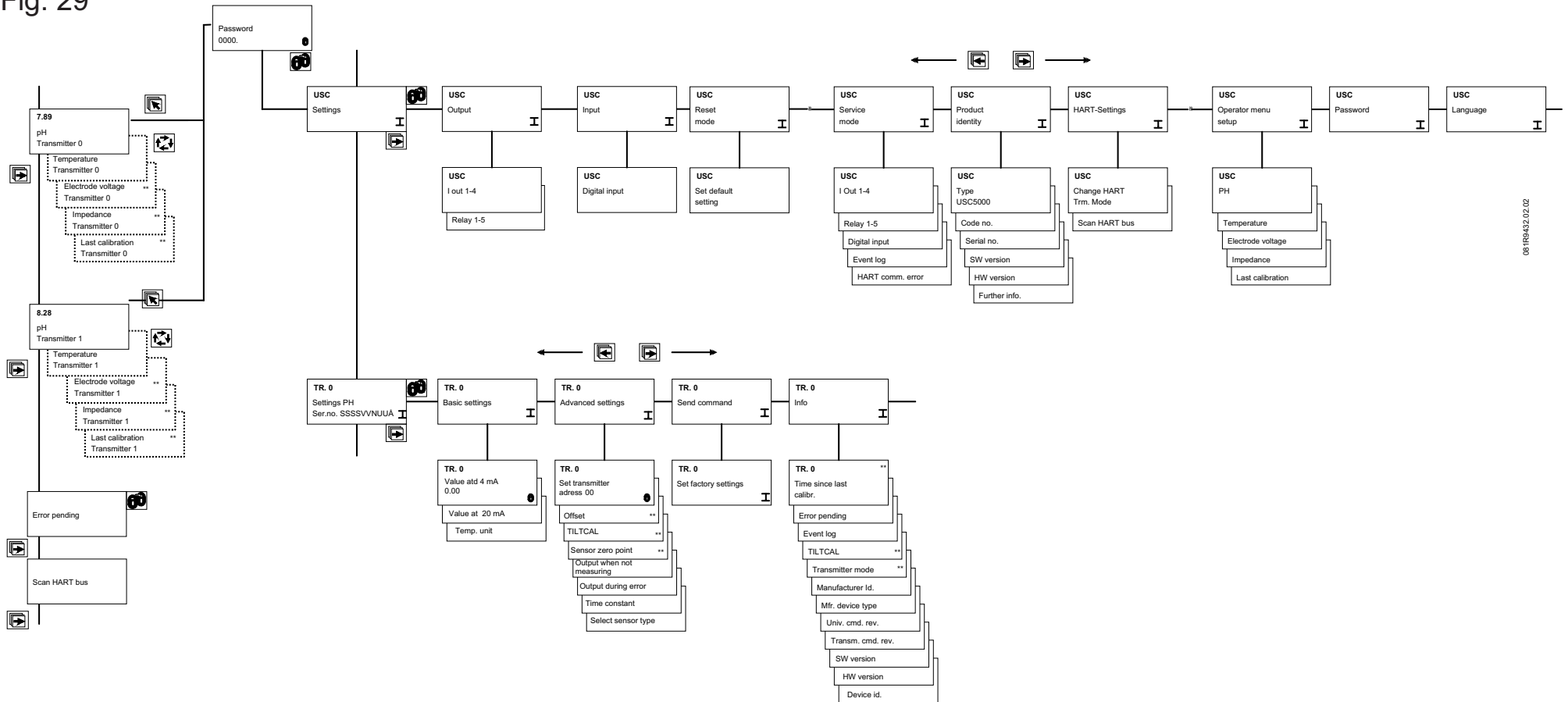

081169432/02.02

USC 7000 multidrop system

Change transmitter address from default

To allow the USC 7000 to recognise the transmitter on the HART® bus, the transmitter needs a unique address between 1 and 15. The EVITA® PH 4100 / REDOX 4100 transmitter is factory delivered with the address 0, which is used for point-to-point installations (USC 5000/6000).

To programme the address of a new transmitter, connect the transmitter to the USC 7000 and press “Scan HART bus”. The transmitter will get the next available address between 1 and 15.

Note: If, before scanning the HART® bus, a transmitter with address higher than 0 was registered as interrupted, the new transmitter will be assigned this address.

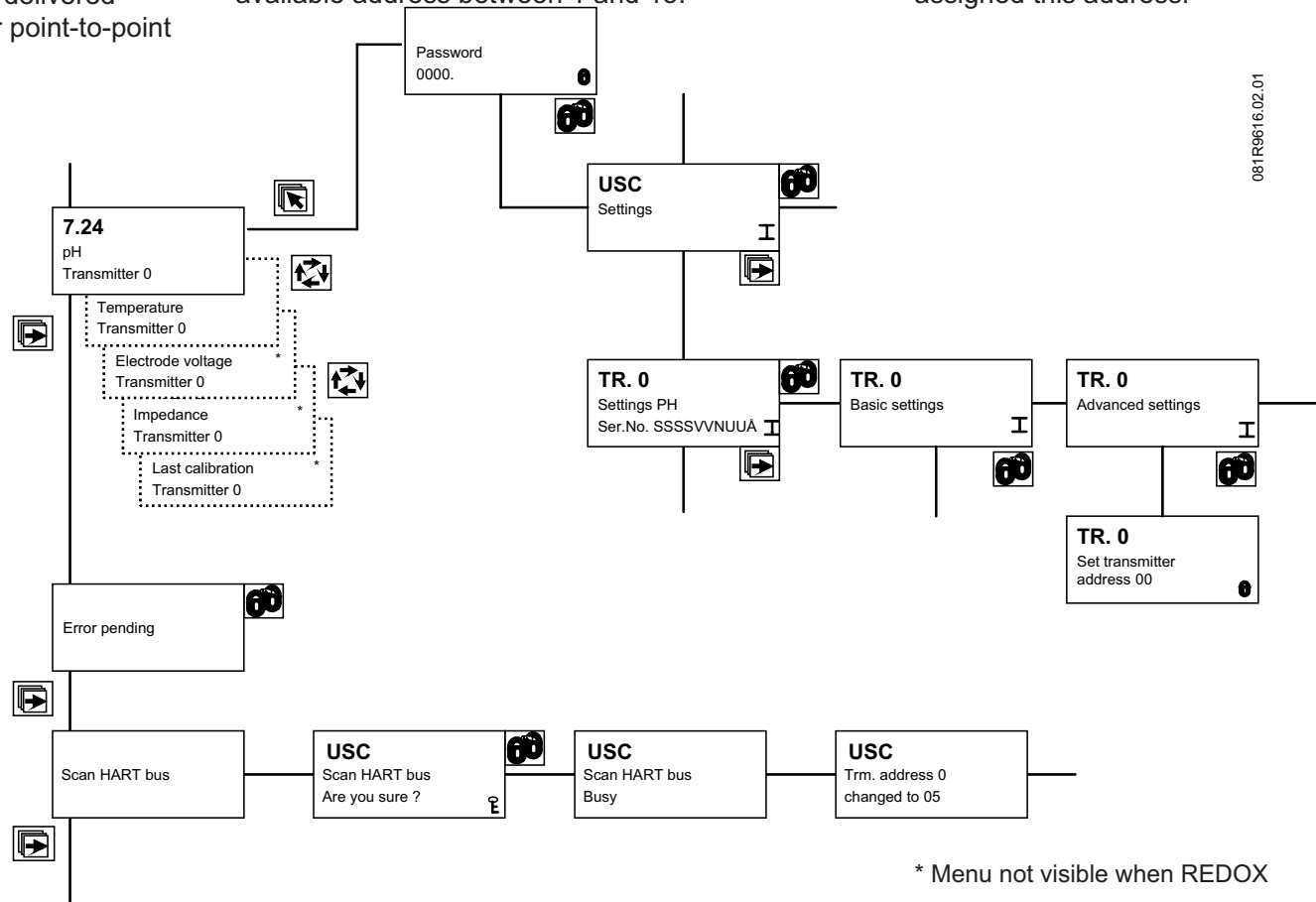

* Menu not visible when REDOX

Fig. 30

Setting of transmitter's current output and temperature unit

If other settings are wanted, the factory settings can be changed as shown below.

Setting of the transmitters measuring unit can be done by changing the value at 4 mA and the value at 20 mA in "Basic settings". Also the display's and current outputs temperature unit can be set in "Basic settings".

However the setting of the USC current outputs range for pH/Redox and temperature is done as shown in fig. 32, p. 26 and fig. 33, p. 27.

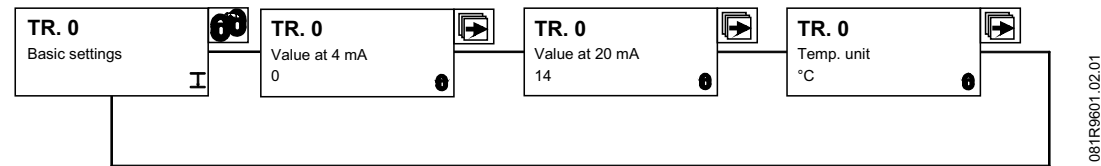
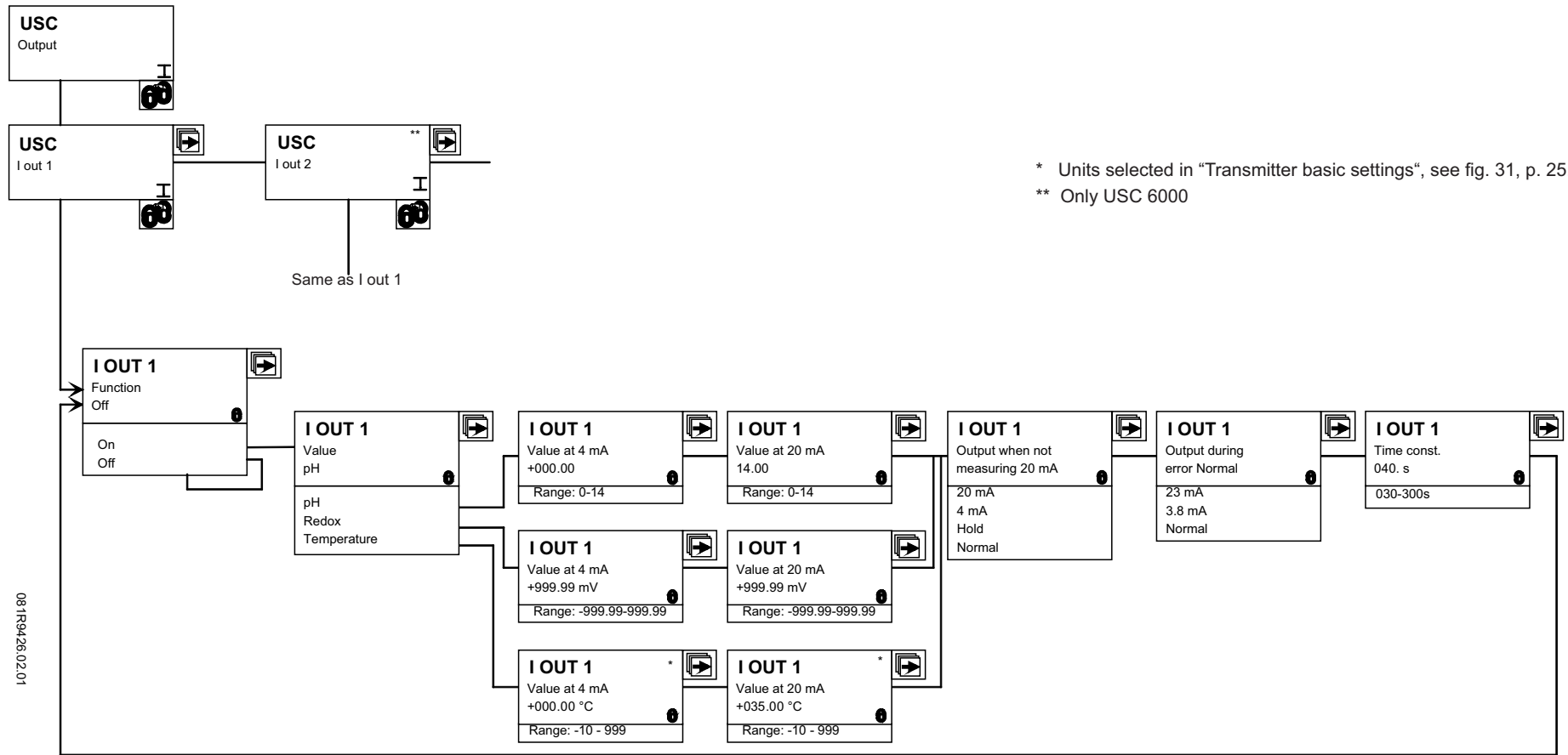

Fig. 31

USC 5000/6000 current output settings

Setting of current output 1 on USC 5000 and current outputs 1 and 2 on USC 6000.

Fig. 32



USC 7000 current output settings

Setting of current outputs 1 to 4 on USC 7000.

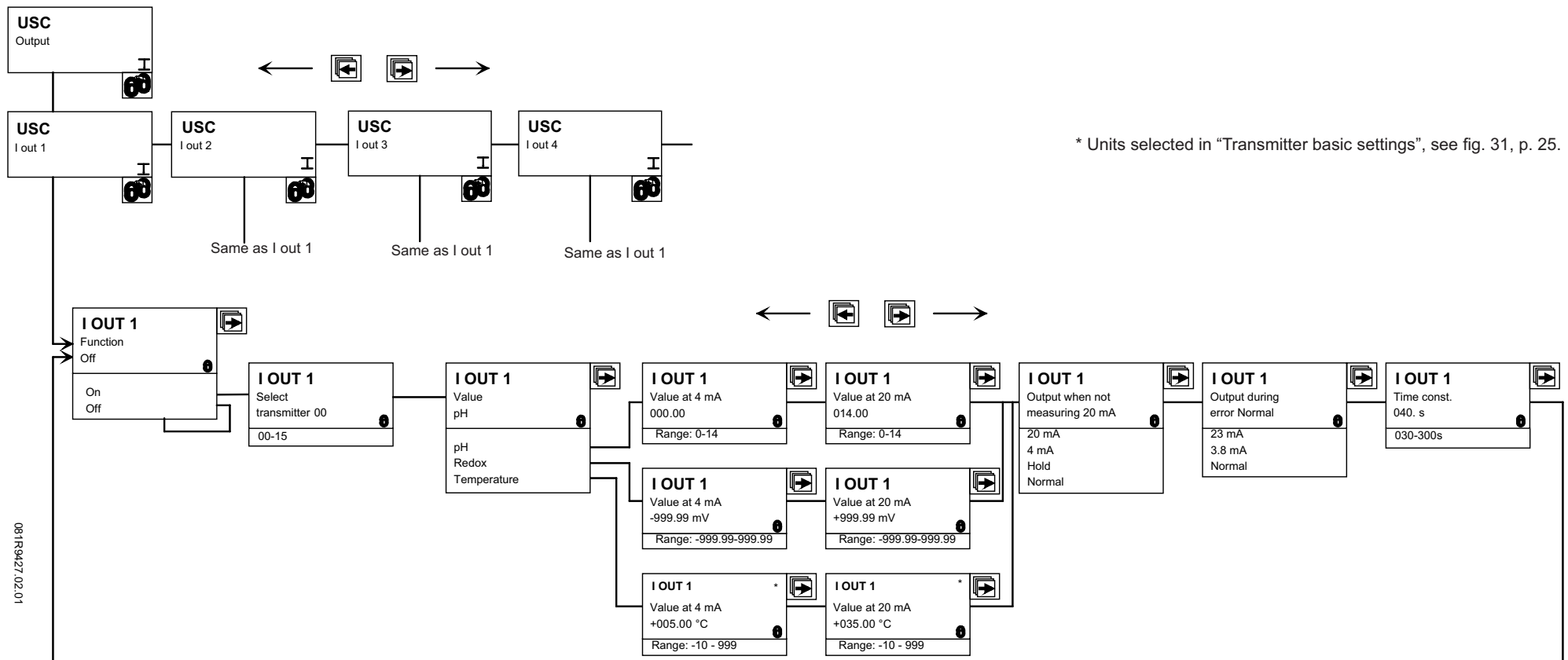

Fig. 33

USC 6000 relay output settings

Setting of relay outputs 1 to 3 on USC 6000.

* Units selected in "Transmitter basic settings" fig. 31, p. 25

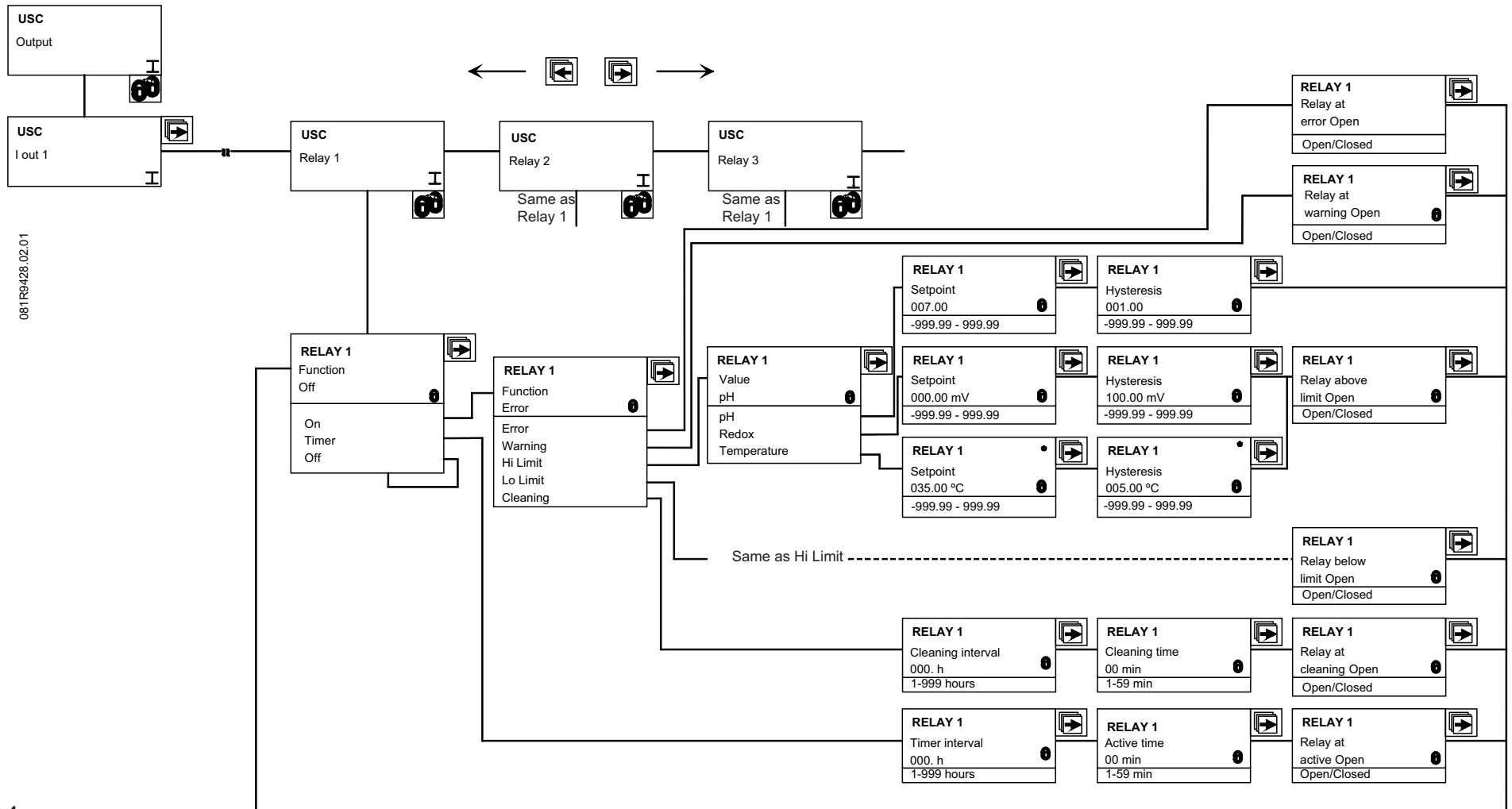

Fig. 34

USC 7000 relay output settings

Setting of relay outputs 1 to 5 on USC 7000

* Units selected in "Transmitter basic setting", fig. 31, p. 25.

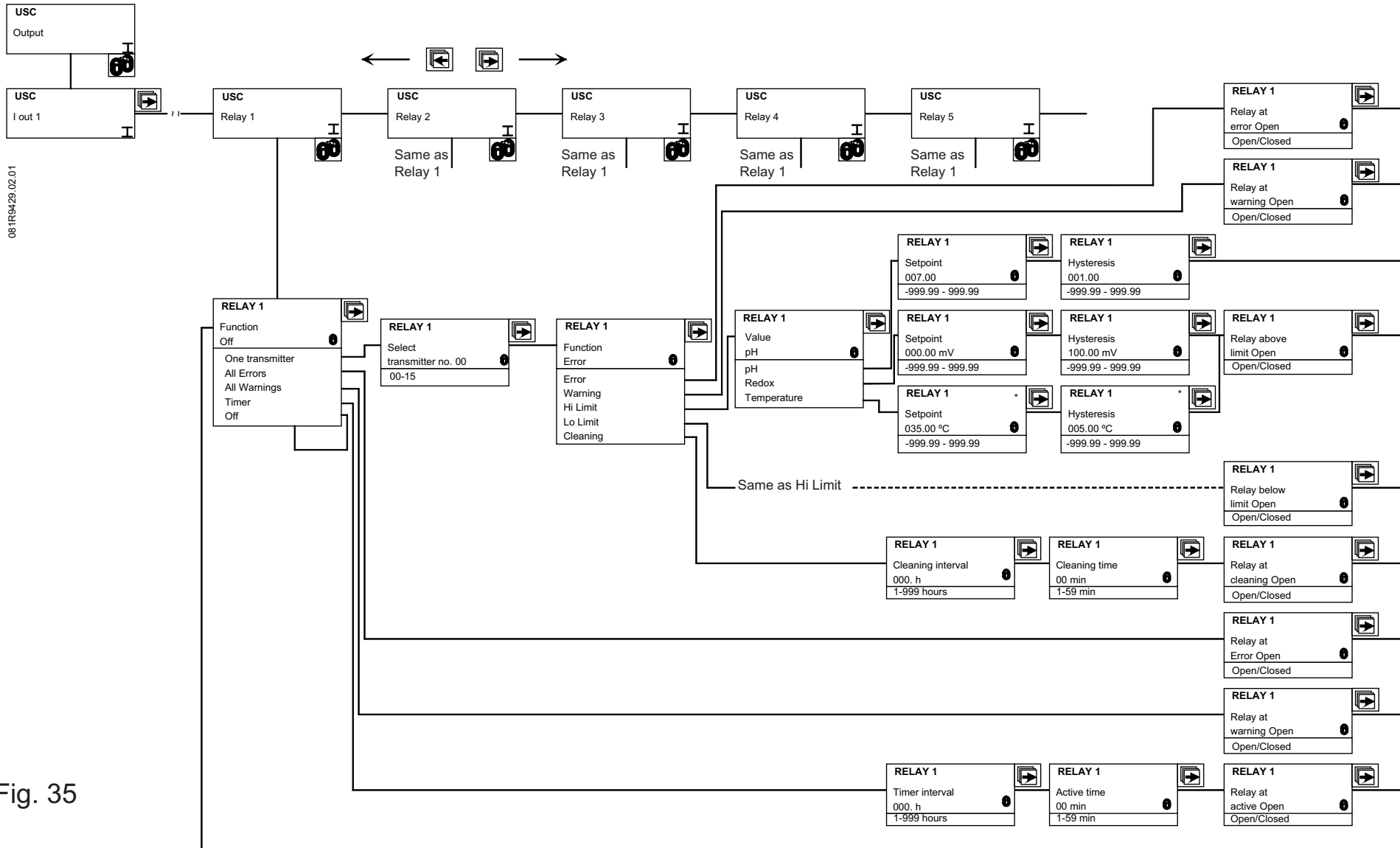

Fig. 35

Calibration (PH only)

EVITA® PH 1100 sensors must be calibrated in buffers with pH 4, 7 and/or 10. Calibration once a month is recommended. The calibration must be performed in new buffers. Dispose the used buffers after each calibration.

Calibration can be initiated by using the TILTCAL® feature in the pH transmitter or by using the ring switch on the pH transmitter.

During calibration, the current output signal is factory set to Hold (the last measured value). Optional 20 mA or 4 mA can be chosen via the USC 5000/6000/7000.

Calibration must be performed to correct the zero point and the slope. The calibration can be performed in 1, 2 or 3 different buffers. Calibration in one buffer corrects the zero point only, while calibration in 2 or 3 buffers corrects both the zero point and the slope.

If the calibration fails, the pH transmitter will continue measuring using the values from the previous calibration.

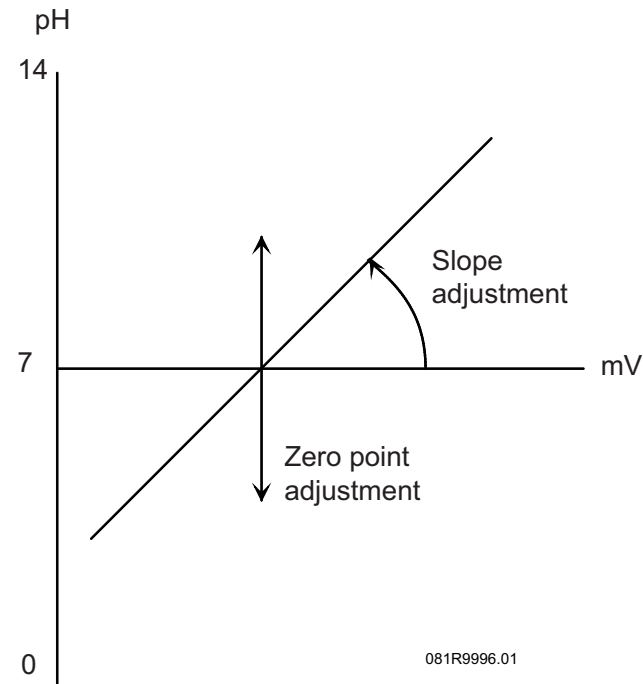
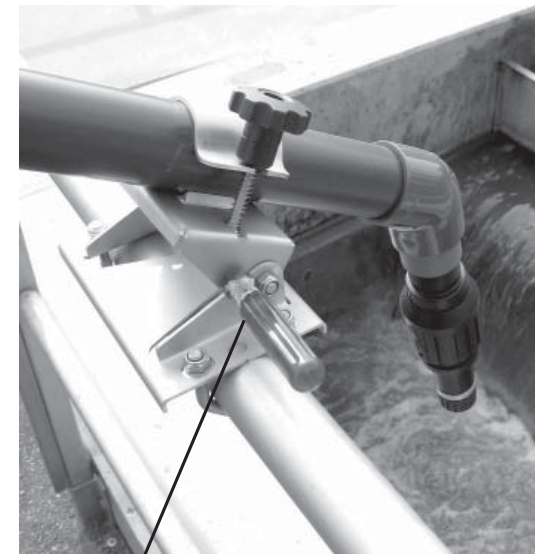

Fig. 36

During calibration, ensure that the PH 1100 sensor, the PH 4100 transmitter and the buffers all have the same temperature.

Before calibration, the PH 1100 sensor must be cleaned, see section "Maintenance", p. 34.



Possibly lock the mounting bracket during calibration using a screwdriver.

Using TILTCAL®

1. Clean the transmitter as described in section "Maintenance", p. 34. Rinse the PH 1100 sensor with distilled water. The light diode flashes once every 5 seconds.



2. Hold the transmitter with the PH 1100 sensor upwards for 30 seconds to initiate calibration by activating the tilt switch.



3. When the transmitter is ready for calibration, the light diode flashes 3 times every 5 seconds.



4. Insert the transmitter in the buffer. The transmitter automatically detects which buffer (4, 7 or 10) is used for calibration.



5. When the transmitter has been adjusted to the correct zero point or slope, the light diode flashes once every 5 seconds.

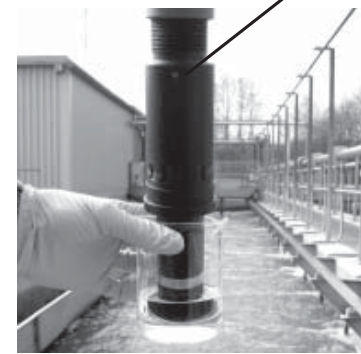

6. If calibration in more than one buffer is to be performed, repeat item 1 to 5 for each buffer. If no further calibration is to be performed, insert the transmitter in the measuring media. The transmitter will automatically start measuring.

Important: Rinse the PH 1100 sensor thoroughly with distilled water before inserting the sensor in the next buffer.

Note: Ensure that the PH 1100 sensor is kept wet to prevent it from drying out and becoming damaged.

Using the ring switch

1. Clean the transmitter as described in section "Maintenance", p. 34. Rinse the PH 1100 sensor with distilled water. The light diode flashes once every 5 seconds.



2. Turn the ring switch so the mark is at 4, 7 or 10, depending on the buffer.



3. Wait until the light diode flashes 3 times every 5 seconds, indicating that the transmitter is ready for calibration.



4. Insert the transmitter in the right buffer. The light diode will continue flashing 3 times every 5 seconds.



5. When the transmitter has been adjusted to the correct zero point or slope, the light diode flashes twice every 5 seconds.



6. If calibration in one or two other buffers is to be performed, repeat item 1 to 5 for each buffer.

7. When calibration is completed, turn the ring switch to mark M (Measuring). After 5 seconds the light diode will start flashing once every 5 seconds indicating that the transmitter is measuring. Insert the transmitter in the measuring media.



Important: Rinse the PH 1100 sensor thoroughly with distilled water before inserting the sensor in the next buffer.

Note: Ensure that the PH 1100 sensor is kept wet to prevent it from drying out and becoming damaged.

Maintenance

Under normal conditions, the PH 1100 / REDOX 1100 sensor will operate for more than 1 year and can be replaced in a few minutes.

General maintenance of the EVITA® PH 1100 / REDOX 1100 sensor is limited to regular cleaning about every two weeks and calibration every month, depending on application.

Cleaning (transmitter/sensor)

During cleaning, the PH 1100 sensor must **not** point upwards for more than 30 seconds at a time if the TILTCAL® function is enabled and the ring switch is removed from the transmitter. Otherwise a calibration cycle will start. The TILTCAL® function can be disabled according to fig. 42, p. 39.

1. Lift the transmitter out of the medium.
2. Clean the sensor with pure water.
 - If the sensor is covered with grease, use pure water to which a little cleaning agent/washing up liquid can be added, or use a 10% HCl (hydrochloric acid) solution for cleaning.
 - If the sensor is covered with a film of protein, use a pepsin solution for cleaning.
 - If the sensor is blocked by calcium, use a 10% HCl (hydrochloric acid) solution for cleaning.
3. Immerse the transmitter into the medium to be measured.

Cleaning (signal converter)

When considered necessary, clean the USC signal converter using a soft moist cloth.



Replacement of sensor

1. Remove the defective/worn PH 1100 / REDOX 1100 sensor. The worn sensor can be disposed as ordinary industrial waste.
2. Insert new sensor (see fig. 37).
3. Perform calibration (see section "Calibration", p. 30-33).

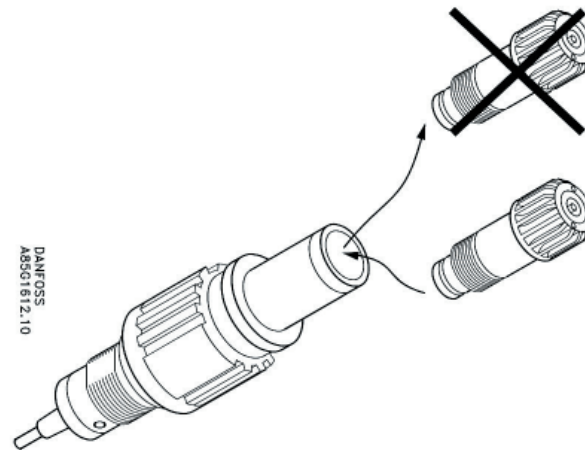

Fig. 37

System information

Transmitter information

In the menu "Info" it is possible to view various information about the transmitter, e.g. time since last calibration, transmitter mode and software and hardware versions.

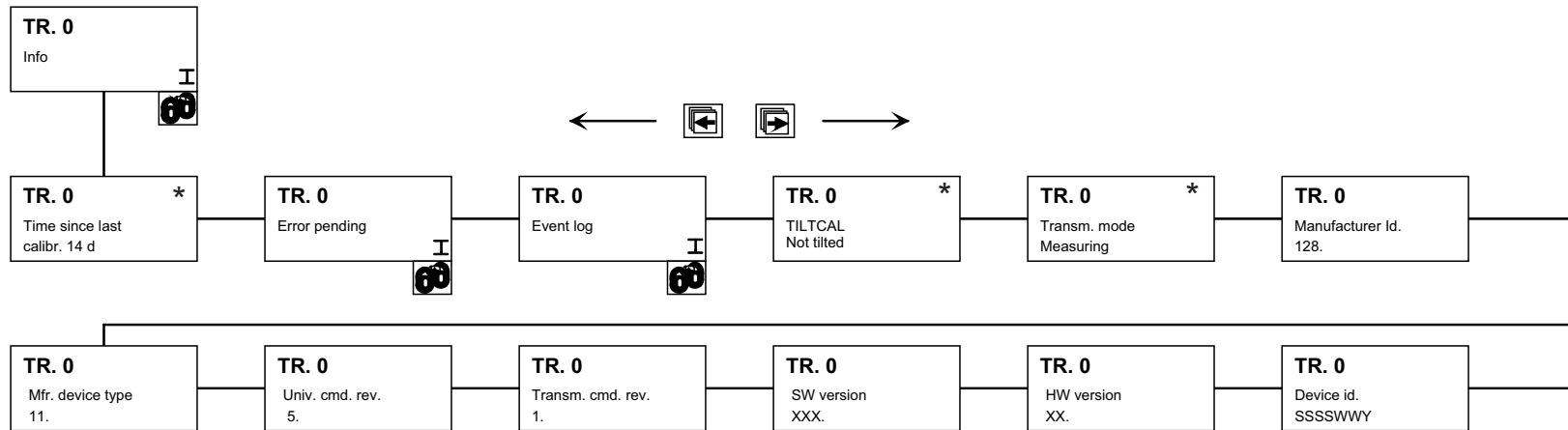

Fig. 38

* Menu not visible when REDOX

Other Menus

Operator menu setup

In the “Operator menu setup” it is possible to hide all menus except “pH” / ”Redox” in the operator menu.

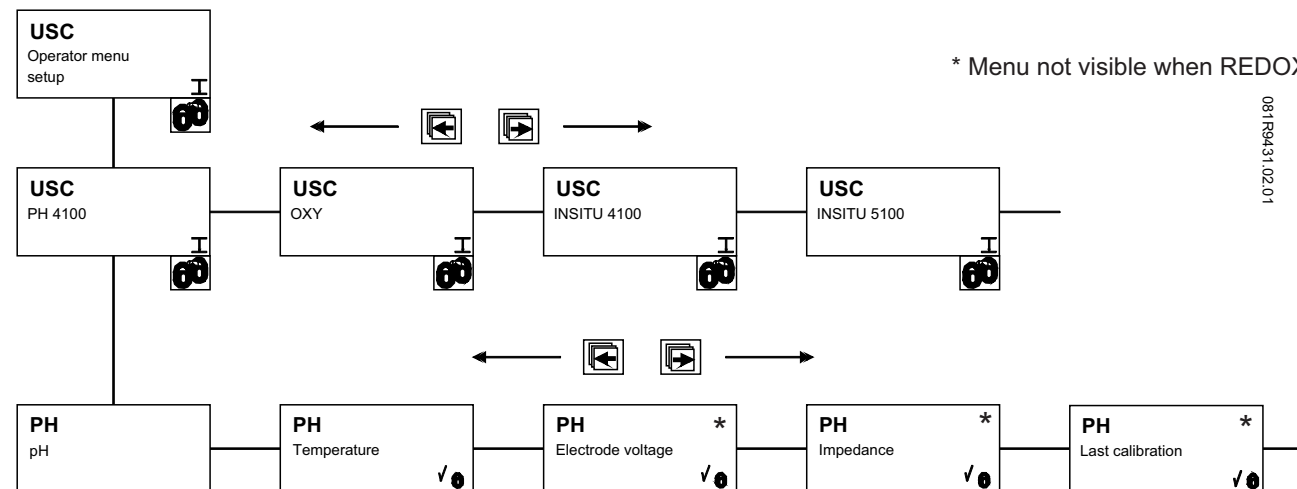

Fig. 40

- A ✓ in the operator menu setup means that this reading is shown in the operator menu.
- A ✗ in the operator menu setup means that this reading is not available when viewing the operator menu.

Advanced settings

In the “Advanced settings” menu it is possible to set an offset on the pH level. If the measured value does not correspond to the expected value, the offset can be adjusted. “Transmitter address” has to be 0 for current output to function in a point-to-point installation using USC 5000 or 6000. When operating in multidrop system using USC 7000, the transmitter must have a unique address between 1 and 15.

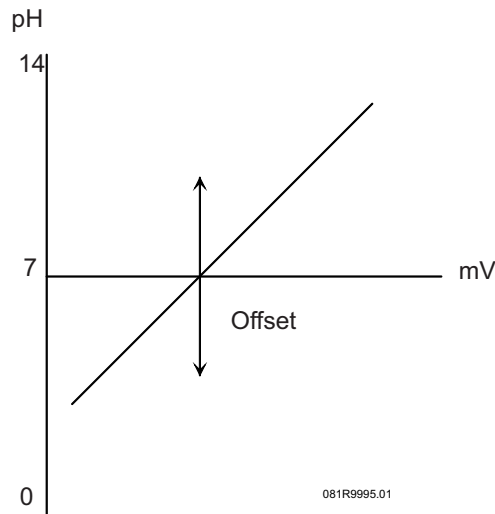
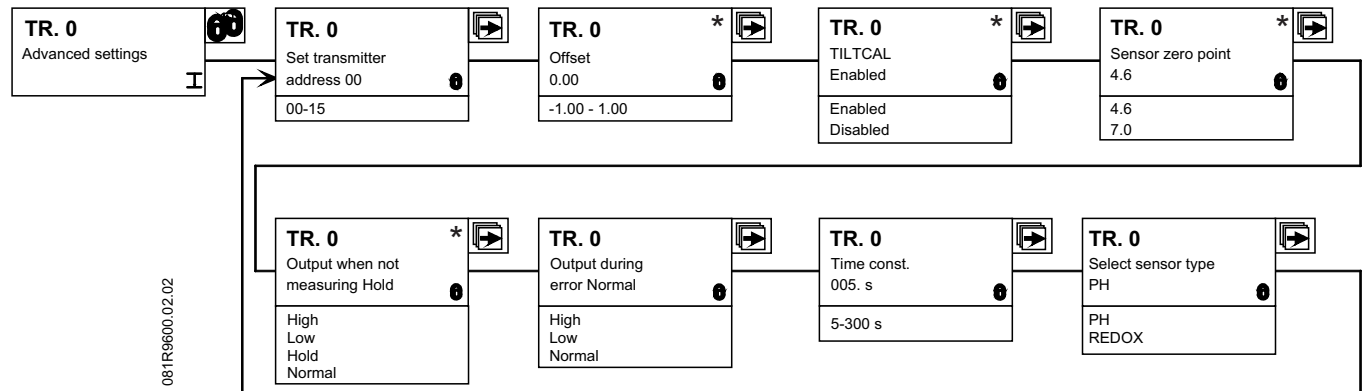

Fig. 41

The measurement start after calibration can be set to either “Manual start” or “Automatic start”. Manual start means that the measurement is initiated from the USC keypad. The TILTCAL® can be disabled in the “Advanced settings” menu. If a PH 1100 sensor with another zero point is mounted, this must be keyed in.

If the PH 1100 sensor is replaced by a REDOX 1100 sensor, this must be keyed in. When the sensor type is changed, the USC will rescan the HART® bus and the USC will return to the operator menu showing the menu concerning the REDOX transmitter.



* Menu not visible when REDOX

Fig. 42

Service mode

In the "Service mode" it is possible to control the relay and the current outputs directly. This may be useful when e.g. a control loop is to be adjusted or if an alarm signal should be checked.

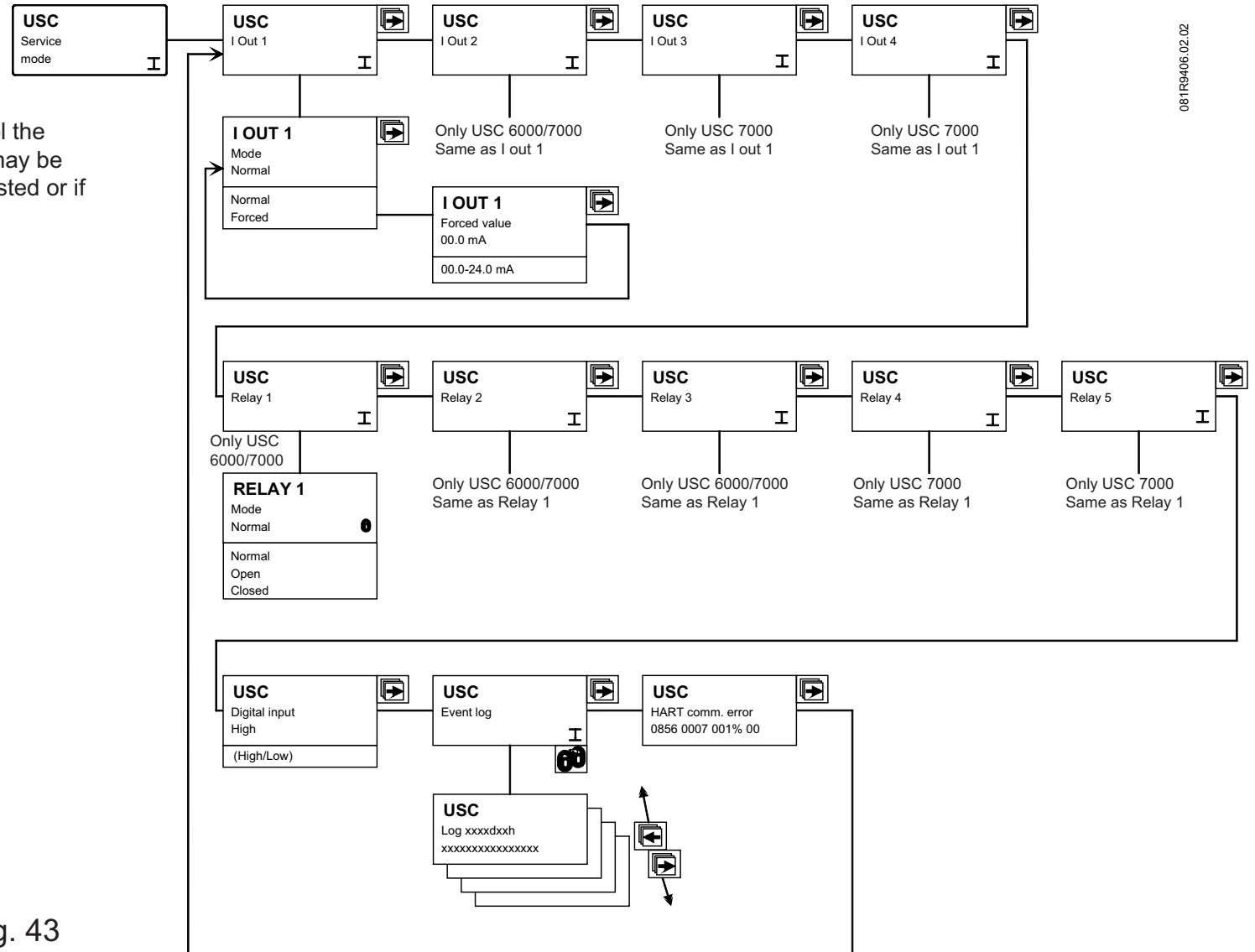

081R9406.02.02

Fig. 43

Reset mode

The factory settings can be re-established as shown in fig. 44.

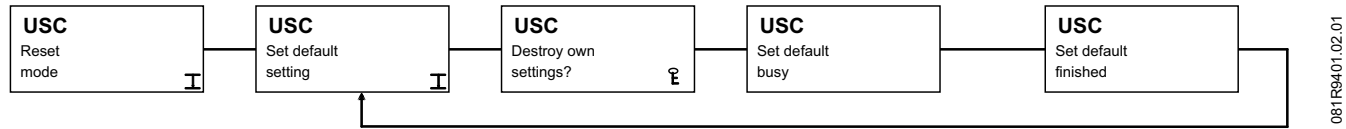

081R94.01.02.01

Fig. 44

Send command

In the "Send command" menu it is possible to set factory settings.

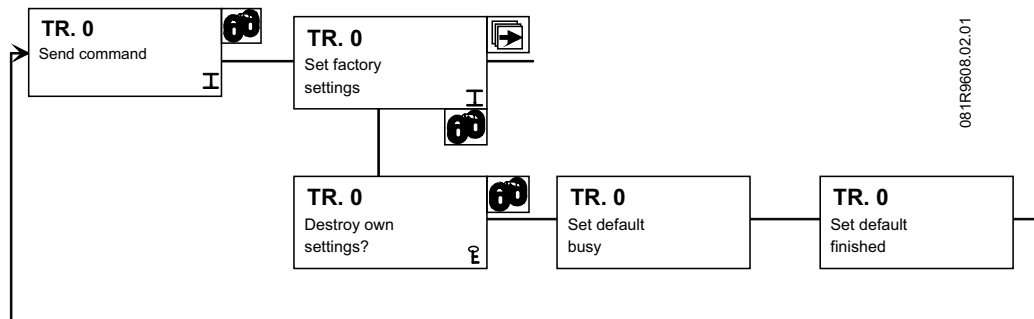



081R9608.02.01

Fig. 45

Troubleshooting

Error system

The EVITA® PH / REDOX has an advanced self-diagnostic system. If there is an error or a warning, a flashing bell  is displayed. To view the pending error information, press the  key in the operator menu – see fig. 46 below.

The USC and the transmitter each has an 'event log' that stores past errors, information and warnings. To access the USC event log, see fig. 43, p. 40. To see the transmitter event log, see fig. 38, p. 36.

For a complete list of events, see troubleshooting guide p. 44-48.

Fig. 46

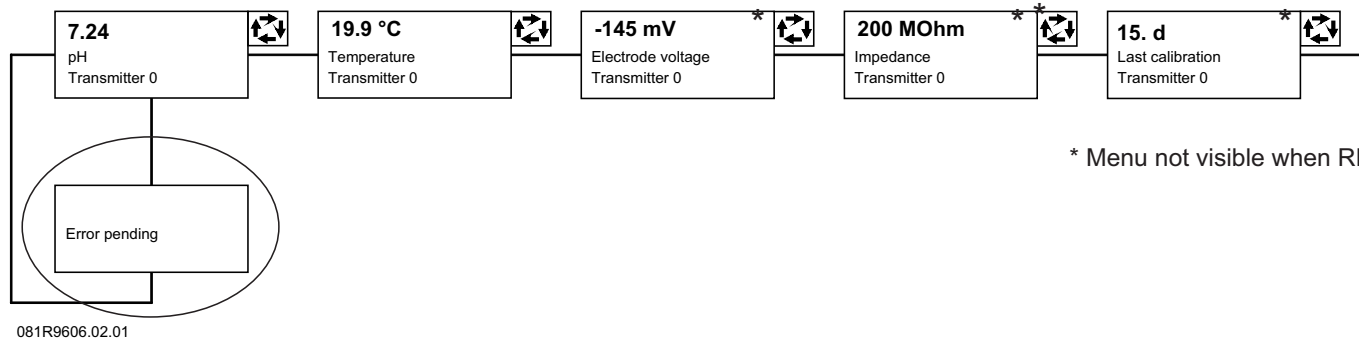

* Menu not visible when REDOX

Each event has an unambiguous identification consisting of 4 digits:

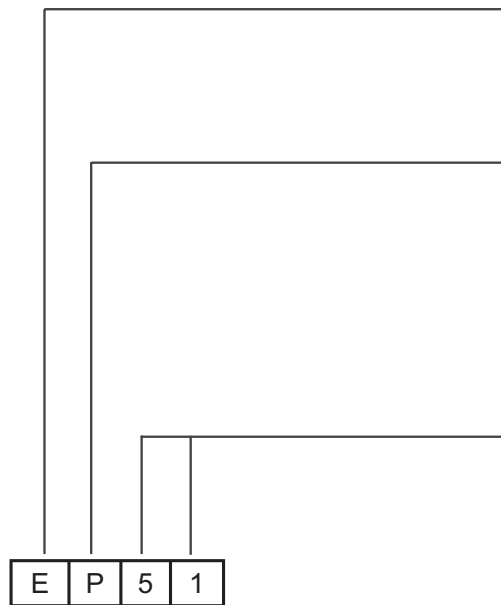

EP51: Impedance is too low

1. digit: Category
I (Information);
W (Warning);
E (Error)
2. digit: Sensor type
U for USC;
O for OXY;
I for INSITU 4100;
N for INSITU 5100;
P for PH/REDOX
T for TMS
S for TSS
3. and 4. digit:
Error number 00-99
The numbers are describing the following events:
00-09 Information
10-49 Warning
50-99 Error

Information

The system will continue to measure as usual. Relay and output signals will not be affected.

Warning

The system will continue to measure, but there has been an event, which may cause malfunction of the system, and which may require an operator. The reason for the warning may disappear on its own. Warning relay, if defined, will show warning in accordance with the setup.

Error

The whole system or part of it is malfunctioning, and the output signal is not reliable anymore. The errors require an operator. Error relays, if defined, will show error in accordance with the setup.

The EVITA® PH 4100 / REDOX 4100 transmitter error pending list shows the 15 first occurred errors that are still pending and the event log shows the 40 latest events, i.e. information, warnings and errors.

The USC signal converter error pending list can show up to 14 pending errors and warnings, displayed with the USC errors first and then the transmitter errors. If there are more than 14 pending errors, the message “Additional errors cannot be viewed” will show in the display. The USC event log shows the 9 latest events.

Troubleshooting guide - PH 4100 (REDOX) stand alone transmitter

Symptom	Current signal	Fault	Remedy
Constant current signal (varying pH / redox level)	I = 0 mA	Incorrect wiring	Check wiring and make the necessary corrections.
		Undervoltage	Check the supply voltage at transmitter. Supply voltage must be at least 12 V.
		Transmitter defective	Replace transmitter
	I = 3.80 mA	Undervoltage	Check the supply voltage at transmitter. Supply voltage must be at least 12 V.
		Transmitter defective	Replace transmitter
	I = 3.85 mA	PH 1100 / REDOX 1100 sensor defective	Replace PH 1100 / REDOX 1100 sensor.
		Temperature <-20°C (-4°F)	Accuracy reduced
		Temperature >+60°C (140°F)	Accuracy reduced
	I = 3.90 mA	Calibration not possible 1. Incorrect buffer is used 2. PH 1100 sensor is dirty 3. PH 1100 sensor is worn or defective	1. Check the buffer 1. Clean transmitter and sensor, see section "Maintenance", p. 34. Recalibrate. 3. Replace PH 1100 sensor.
	I = 3.95 mA	pH / redox level under set measuring range	Set the lower measuring limit to a lower value.
I = 4.00 mA	Initialisation fault	1. Switch off transmitter for min. 5 seconds. 2. Switch on again while sensor points downwards.	
I = 22.00 mA	pH / redox level above set measuring range	Set the upper measuring limit to a higher value.	
Error in measuring value	Variable	PH 1100 / REDOX 1100 sensor is dirty or worn	1. Clean transmitter and sensor, see section "Maintenance", p. 34. 2. If PH - calibrate.

Troubleshooting guide - PH 4100 / REDOX 4100 transmitter

Symptom	Current output signal	Event code	Cause	Remedy
Error in measuring value	Variable		PH 1100 / REDOX 1100 sensor is dirty or worn	1. Clean transmitter and sensor, see section "Maintenance", p. 34. 2. If PH - calibrate. 3. Replace PH 1100 / REDOX 1100 sensor.
Display switching between "pH" and "End of calibration"			End of calibration phase	Go to "Send command" menu and start measuring, see fig. 45, p. 41
Flashing bell in display 	Depending on the settings	WP10	The measured value has exceeded the transmitter output setting	Change value at 20 mA in "Basic settings", see fig. 31, p. 25
		WP11	The measured value is below the transmitter output setting	Change value at 4 mA in "Basic settings", see fig. 31, p. 25
		WP20	The temperature is below -20°C (-4°F)	The accuracy might be reduced.
		WP21	The temperature is above 60°C (140°F)	The accuracy might be reduced.
		EP51	Impedance too low	1. Clean transmitter and sensor, see section "Maintenance", p. 34. If PH - calibrate 2. Replace PH 1100 / REDOX 1100
		EP52	Impedance too high	1. Clean transmitter and sensor, see section "Maintenance", p. 34. If PH - calibrate 2. Replace PH 1100 / REDOX 1100
		EP53	Error in the input circuit	Replace transmitter
		EP60	Error in EEPROM	Replace transmitter
		EP61	Error in communication between the μ -controller and the A/D converter or error in the A/D converter	Replace transmitter
		EP70	Calibration not possible. 1. Incorrect buffer is used 2. PH 1100 is dirty 3. PH 1100 is worn or defective 4. PH 4100 is defective	1. Check buffer 2. Clean transmitter and sensor, see section "Maintenance", p. 34. Recalibrate 3. Replace PH 1100 4. Replace transmitter
		EP71	Calibration not possible - same as EP70	Same as EP70
		EP72	Calibration not possible - same as EP70	Same as EP70
EP73	Calibration not possible - same as EP70	Same as EP70		

Troubleshooting guide - signal converter

Symptom	Current output	Event code	Cause	Remedy
None	Undefined	IU00	Power on	Registration of time of power on
		IU01	Add-on module applied	Registration of applied add-on module
		IU02	Add-on module defective or removed	Replace or install add-on module
		IU03	Parameter successfully corrected	Information
Empty display			1. Supply voltage 2. USC 5000/6000/7000 defective	1. Check supply voltage 2. Replace USC 5000/6000/7000
Dots in upper line of display	I out 1 I out 2 I out 3 I out 4	EU61 EU62 EU63 EU64	See EU61, page 47 See EU62, page 47 See EU63, page 47 See EU64, page 47	Same as EU61
Flashing bell in display 	Undefined	WU10	I out 1: Value at 4 mA \geq Value at 20 mA	Check I out 1 setup
		WU11	I out 2: Value at 4 mA \geq Value at 20 mA	Check I out 2 setup
		WU12	I out 3: Value at 4 mA \geq Value at 20 mA	Check I out 3 setup
		WU13	I out 4: Value at 4 mA \geq Value at 20 mA	Check I out 4 setup
		WU14	The measured value has exceeded the current output 1 setting	Change value at 20 mA on I out 1
		WU15	The measured value has exceeded the current output 2 setting	Change value at 20 mA on I out 2
		WU16	The measured value has exceeded the current output 3 setting	Change value at 20 mA on I out 3
		WU17	The measured value has exceeded the current output 4 setting	Change value at 20 mA on I out 4
		WU18	The measured value is below the current output 1 setting	Change value at 4 mA on I out 1
		WU19	The measured value is below the current output 2 setting	Change value at 4 mA on I out 2
		WU20	The measured value is below the current output 3 setting	Change value at 4 mA on I out 3
WU21	The measured value is below the current output 4 setting	Change value at 4 mA on I out 4		

Symptom	Current output	Event code	Cause	Remedy
Flashing bell in display 	Undefined	WU39	HART® communication error	Check cables
		WU40	TMS communication error	Replace TMS
		WU41	A parameter is out of range. It could not be replaced by its default value	Fixed at power-up
		WU43	Too many errors at the same time. Some errors are not registered correctly	Power-up USC
		WU49	Internal error	Power-up USC
	One or more current outputs = 3.8 mA or 24 mA	EU60	CAN bus application does not respond. This error is shown when the maximum number of communication attempts is exceeded	1. Power-up USC 2. Replace USC
	Undefined	EU61	USC unable to read data required for I OUT 1 1. No reply from transmitter 2. Transmitter has got new address 3. Another master conflicts on HART® comm. 4. Supply voltage for transmitter too low 5. Too much noise on current loop 6. Transmitter defective 7. USC defective	1. Check shielding and cable connections 2. Power-up USC 3. Disconnect the other master or set USC to another master, see fig. 47, p. 53 4. Check supply voltage at transmitter, supply voltage must be at least 20 V 5. Check shielding and cable connections 6. Replace transmitter 7. Replace USC
		EU62	USC unable to read data required for I OUT 2 1 - 7: Same as EU61	Same as EU61
		EU63	USC unable to read data required for I OUT 3 1 - 7: Same as EU61	Same as EU61
		EU64	USC unable to read data required for I OUT 4 1 - 7: Same as EU61	Same as EU61

Symptom	Current output	Event code	Cause	Remedy
Flashing bell in display 	Undefined	EU65	USC unable to read data required for relay 1 1 - 7: Same as EU61	Same as EU61
		EU66	USC unable to read data required for relay 2 1 - 7: Same as EU61	Same as EU61
		EU67	USC unable to read data required for relay 3 1 - 7: Same as EU61	Same as EU61
		EU68	USC unable to read data required for relay 4 1 - 7: Same as EU61	Same as EU61
		EU69	USC unable to read data required for relay 5 1 - 7: Same as EU61	Same as EU61

Technical Data

PH 4100 / REDOX 4100 transmitter

Measuring principle	Potentiometric
Transmitter cable	Two-wire, screened cable 2 x 0.75 mm ² (18 AWG) cable, length 10 m (33')
Supply voltage	Min. 12 Vd.c. - max. 30 Vd.c. HART®: max. ripple (47 Hz - 125 Hz): 0.2 V p-p max. noise (500 Hz - 10 kHz): 1.2 mV rms
Power consumption	Max. 720 mVA
Current output	3.80-24 mA
Time constant	5-300 s (default 5 s)
Digital communication	HART® communication superposed on current output
Alarm signal	On current output
Measuring range	PH: 0-14 REDOX: -1000 mV - +1000 mV
Temperature range	Transmitter: Operation: -20°C - +60°C (-4°F - 140°F) Storage: -20°C - +80°C (-4°F - 176°F)
Accuracy	pH: ± 0.01 Redox: 1 mV
Response time	5 s
pH input	>10 ¹² ohm
Reference impedance	>10 ¹⁹ ohm
Enclosure	IP68 to IEC 529 (10 m); NEMA 6P (30')
Pipe mounting	Max. 5 bar
Dimensions and weight	Length: 250 mm (9.8") Diameter: 60 mm (2.4") Weight: 0.9 kg (2.0 lb)
Materials	FORTRAN®
EMC	Emission: EN 50081 Immunity: EN 50082

PH 1100 sensor

Description	Combined double junction with flat glass membrane
Reference junction	Sintered PTFE
Reference system	Gel: KCl; Double junction
Impedance	50 Mohm at 25°C
Temperature range	Operation: -10°C - +80°C (14°F - 176°F) Storage: -10°C - +80°C (14°F - 176°F)
Estimated lifetime	1-2 years depending on application and maintenance
Dimensions and weight	Length: 100 mm (3.9") Diameter: 40 mm (1.6") Weight: 0.1 kg (0.2 lb)

REDOX 1100 sensor

Description	Combined double junction with Platinum stick
Reference junction	Sintered PTFE
Reference system	Gel: KCl; Double junction
Impedance	2 kohm at 25°C
Temperature range	Operation: -10°C - +80°C (14°F - 176°F) Storage: -10°C - +80°C (14°F - 176°F)
Estimated lifetime	1-2 years depending on application and maintenance
Dimensions and weight	Length: 100 mm (3.9") Diameter: 40 mm (1.6") Weight: 0.1 kg (0.2 lb)

Universal Signal Converter USC 5000/6000/7000

Type	USC 5000	USC 6000	USC 7000
No. of transmitters	1 (point-to-point installation)	1 (point-to-point installation)	15 (multidrop)
Current outputs	One 4-20 mA (scaleable), 24V active galvanic isolated Max. load: 800 ohm	Two 4-20 mA (scaleable), 24V active galvanic isolated Max. load: 800 ohm	Four 4-20 mA (scaleable), 24V active galvanic isolated Max. load: 800 ohm
Relay outputs	None	3 relay outputs SPST (max. 48 Va.c. or 30 Vrms 4 A)	5 relay outputs SPST (max. 48 Va.c. or 30 Vrms 4 A)
Digital input	Min. 12 to max 30 V d.c. (6 KOhm)	Min. 12 to max 30 V d.c. (6 KOhm)	Min. 12 to max 30 V d.c. (6 KOhm)
Display	Back-lit alphanumeric LCD display	Back-lit alphanumeric LCD display	Back-lit alphanumeric LCD display
Enclosure	IP 67 according to IEC 529; NEMA 4X	IP 67, IP 20 according to IEC 529; NEMA 4X	IP 67, IP 20 according to IEC 529; NEMA 4X
Ambient temperature	Storage: -40°C to +70°C (-40°F to 158°F) Operation: -40°C to +60°C (-40°F to 140°F)	Storage: -40°C to +70°C (-40°F to 158°F) Operation: -40°C to +60°C (-40°F to 140°F)	Storage: -40°C to +70°C (-40°F to 158°F) Operation: -40°C to +50°C (-40°F to 122°F)
Environment	Indoor use, altitude up to 2000 m Pollution Degree II Relative humidity 80% up to 31°C (87.8°F) decreasing linearly to 50% at 40°C (104°F)	Indoor use, altitude up to 2000 m Pollution Degree II Relative humidity 80% up to 31°C (87.8°F) decreasing linearly to 50% at 40°C (104°F)	Indoor use, altitude up to 2000 m Pollution Degree II Relative humidity 80% up to 31°C (87.8°F) decreasing linearly to 50% at 40°C (104°F)
Power supply	100-240 V a.c. +10%/-15% 50/60 Hz. 5-20VA Fuse: T500mA/250V (Not to be changed by user)	100-240 V a.c. +10%/-15% 50/60 Hz. 5-20VA Fuse: T500mA/250V (Not to be changed by user)	100-240 V a.c. +10%/-15% 50/60 Hz. 5-20VA Fuse: T500mA/250V (Not to be changed by user)
Cable glands	Jacob GmbH, cat. no. 50.013 PA (PG13.5) 6-12 mm cable diameter (UL approved: 9-12 mm)	Jacob GmbH, cat. no. 50.013 PA (PG13.5) 6-12 mm cable diameter (UL approved: 9-12 mm)	Jacob GmbH, cat. no. 50.013 PA (PG13.5) 6-12 mm cable diameter (UL approved: 9-12 mm)
Blind plugs	Jacob GmbH, cat. no. 1013 PA	Jacob GmbH, cat. no. 1013 PA	Jacob GmbH, cat. no. 1013 PA

Type	USC 5000	USC 6000	USC 7000
Approvals	CE, C-tick and UL approved Emission: EN 50081 Immunity: EN 50082	CE, C-tick and UL approved Emission: EN 50081 Immunity: EN 50082	CE, C-tick and UL approved Emission: EN 50081 Immunity: EN 50082
Option module		TMS option module (Tele Metric System) - Remote communication - Alarm/error monitor with SMS and e-mail service for up to 4 preprogrammed receivers - Built-in real-time clock - 900/1800 MHz GSM - Battery back-up	TMS option module (Tele Metric System) - Remote communication - Alarm/error monitor with SMS and e-mail service for up to 4 preprogrammed receivers - Built-in real-time clock - 900/1800 MHz GSM - Battery back-up

The insulation between mains supply and all input and output terminals of the USC signal converter were provided with double or reinforced insulation by a dielectric strength voltage of 2300 Va.c. Installation category II.

Disposal in accordance with EU directive 2002/96/EC

In compliance with EU directive 2002/96/EC, HACH LANGE / the local subsidiary will accept back and dispose of the old instrument at no cost.



ATTENTION!

It is not allowed to dispose of the instrument using municipal waste disposal services. Please talk to your local HACH LANGE contact.

Important: Before returning goods to HACH LANGE, the products must be cleaned properly.

HART®

The PH 4100 / REDOX 4100 transmitter offers additional features. These features can be accessed through the USC 5000/6000/7000 signal converter or HART® communication. To use HART® communication it is necessary to use a PC or PLC with a HART® modem and associated software.

All *Universal Commands* are fully implemented, as are the necessary *Common Practice Commands*, but to ensure complete utilisation of the transmitter, special *Device Specific Commands* are used.

HART® communication makes it possible to read off:

- pH level
- redox potential
- temperature
- alarms
- indication of completed calibration

When calibrating/replacing a PH 1100 sensor the following can be performed with HART® communication:

- initiation of calibration
- zero setting of life counter

The following programming is possible with HART® communication:

- setting of measuring range
- deactivation of tilt-switch for initiating an automatic calibration
- setting of current output signal during calibration for 4 mA, 20 mA or last measuring value
- deactivation of alarms on current output

The USC 5000/6000/7000 can act as either a primary master or a secondary master. This can be set as shown in fig. 47.

Fig. 47

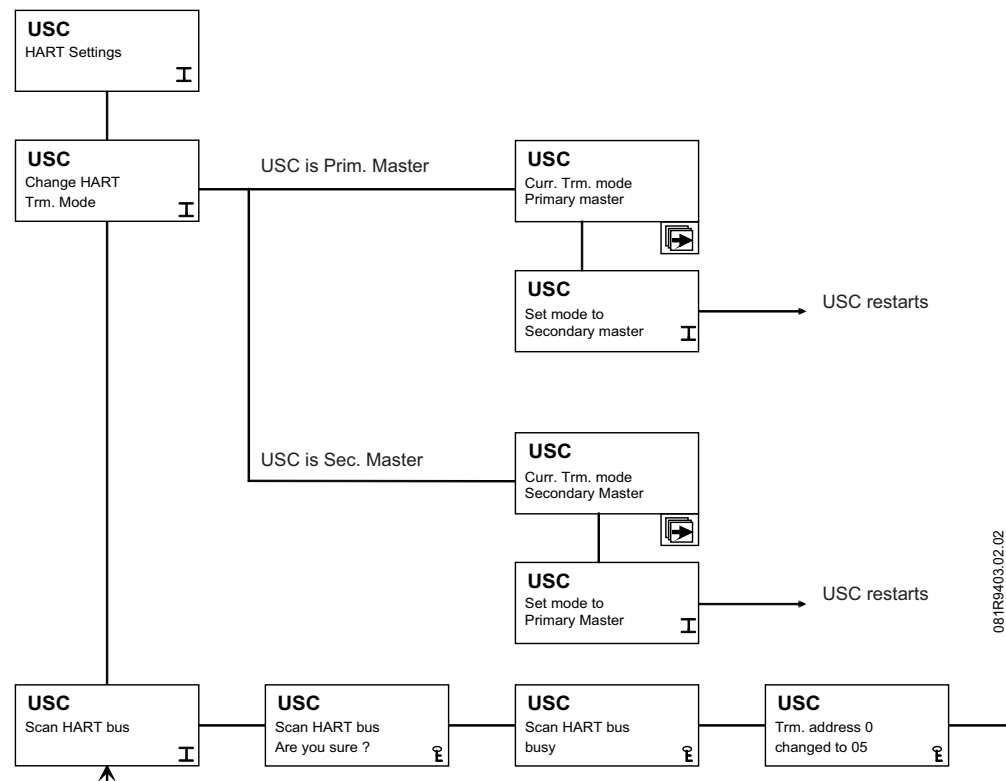

Warranty, liability and complaints

HACH LANGE GmbH warrants that the product supplied is free of material and manufacturing defects and undertakes the obligation to repair or replace any defective parts at zero cost (no guarantee of quality or durability).

At variance with our general terms and conditions, the warranty period for the EVITA series instruments is 12 months.

EVITA INSITU/ EVITA INLINE: On the conclusion of a system care contract within 6 months of purchase, the warranty period is extended based on the terms in the system care contract. HACH LANGE GmbH offers various system care contracts with different services and warranty period extensions.

With the exclusion of the further claims, the supplier is liable for defects including the lack of assured properties as follows: all those parts that, within the warranty period calculated from the day of the transfer of risk, can be demonstrated to have become unusable or that can only be used with significant limitations due to a situation present prior to the transfer of risk, in particular due to incorrect design, poor materials or inadequate finish will be improved or replaced, at the supplier's discretion. The identification of such defects must be notified to the supplier in writing without delay, however at the latest 14 days after the identification of the fault. If the customer fails to notify the supplier, the product is considered approved despite the defect. Further liability for any direct or indirect damages is not accepted.

If instrument-specific maintenance and servicing work defined by the supplier is to be performed within the warranty period by the customer (maintenance) or by the supplier (servicing) and these requirements are not met, claims for damages due to the failure to comply with the requirements are rendered void.

HACH LANGE is not responsible for any indirect or consequential damages, e.g. injuries or damage to property, failure in operation, including loss of production, loss of profits, loss of goods in stock or similar that could result from defects and/or delayed delivery of products sold, irrespective of the cause including faulty manufacture, design and materials.

Furthermore, the warranty does not include:

- Wearing parts and consumables
- If the product is damaged because it was not operated/maintained in accordance with the manual
- If the product is damaged due to incorrect installation or operation
- Damage caused by electrical failure or lightning/ overvoltage
- Defects resulting from failure to clean prior to storage
- Defects due to use outside the specifications for the transmitter

The following points are to be undertaken (even without a system care contract) by the customer:

- Attention! EVITA INSITU 4100 / EVITA INSITU 2100 / EVITA INLINE 4150:
 - o The transmitter is to be cleaned with a cleaning cartridge prior to every chemical change
- Documentation of the cleaning and maintenance work performed
- The replacement of a transmitter supplied
- The cleaning, packaging and organisation of the return of the faulty transmitter to HACH LANGE for repair and/or troubleshooting

HACH LANGE GmbH process instruments are of proven reliability in many applications and are therefore often used in automatic control loops to provide the most economical possible operation of the related process.

To avoid or limit consequential damage, it is therefore recommended to design the control loop such that a malfunction in an instrument results in an automatic change over to the backup control system; this is the safest operating state for the environment and the process.

If not otherwise agreed, the general terms and conditions of HACH LANGE GmbH also apply

Contacts

Please find below the extract of HACH LANGE companies. Other company locations:
www.hach-lange.com

HACH LANGE GmbH
Willstätterstraße 11
D-40549 Düsseldorf
Tel. +49 (0) 211- 52 88 - 0
Fax +49 (0) 211- 52 88 - 143
info@hach-lange.de
www.hach-lange.de

HACH LANGE LTD
Pacific Way
Salford
Manchester, M50 1DL
Tel. +44 (0)161 8 72 14 87
Fax +44 (0)161 8 48 73 24
info@hach-lange.co.uk
www.hach-lange.co.uk

HACH LANGE
HACH SAS
33, Rue du Ballon
F-93165 Noisy Le Grand
Tél. +33 (0)1 48 15 8080
Fax +33 (0)1 48 15 80 00
info@hach-lange.fr
www.hach-lange.fr

DR. BRUNO LANGE
GES. MBH
Industriestraße 12
A-3200 Obergrafendorf
Tel. +43 (0) 2747 - 74 12
Fax +43 (0) 2747 - 42 18
info@hach-lange.at
www.hach-lange.de

DR. BRUNO LANGE AG
Juchstrasse 1
CH-8604 Hegnau
Tel. +41 (0)44- 9 45 66 10
Fax +41 (0)44- 9 45 66 76
info@hach-lange.ch
www.hach-lange.ch

HACH LANGE SA
Motstraat 54
B-2800 Mechelen
Tél. +32 (0)15 42 35 00
Fax +32 (0)15 41 61 20
info@hach-lange.be
www.hach-lange.be

DR. LANGE NEDERLAND B.V.
Laan van Westroijen 2a
NL-4003 AZ Tiel
Tel. +31(0)3 44 63 11 30
Fax +31(0)3 44 63 11 50
info@hach-lange.nl
www.hach-lange.nl

HACH LANGE AB
Vinhundsvägen159A
S-128 62 Sköndal
Tel. +46 (0)8 7 98 05 00
Fax +46 (0)8 7 98 05 30
info@hach-lange.se
www.hach-lange.se

HACH LANGE A/S
Åkandevej 21
DK-2700 Brønshøj
Tel. +45 36 77 29 11
Fax +45 36 77 49 11
info@hach-lange.dk
www.hach-lange.dk

HACH LANGE S.L.U.
C/Araba 45, Apdo. 220
E-20800 Zarautz/Guipúzcoa
Tel. +34 9 43 89 43 79
Fax +34 9 43 13 02 41
info@hach-lange.es
www.hach-lange.es

HACH LANGE SP.ZO.O.
ul. Opolska 143 a
PL-52-013 Wroclaw
Tel. +48 71 3 42 10-81
Fax +48 71 3 42 10-79
info@hach-lange.pl
www.hach-lange.pl

HACH LANGE S.R.L.
Via Riccione, 14
I-20156 Milano
Tel. +39 02 39 23 14-1
Fax +39 02 39 23 14-39
info@hach-lange.it
www.hach-lange.it

HACH LANGE S.R.O.
Lešanská 2a/1176
CZ-141 00 Praha 4
Tel. +420 272 12 45 45
Fax +420 272 12 45 46
info@hach-lange.cz
www.hach-lange.cz

HACH LANGE S.R.O.
Sabinovská 10
SK-821 02 Bratislava
Tel. +421 2 4820 9091
Fax +421 2 4820 9093
info@hach-lange.sk
www.hach-lange.com

HACH LANGE LDA
Rua dos Malhães,
Edif. D. Pedro I
P-2770-071 Paço D'Arcos
Tel. +351 210 00 1750
Fax +351 210 00 8140
info@hach-lange.pt
www.hach-lange.pt