

DOC023.52.00080.Jun05

EVITA[®] TSS

User Manual



LANGE 

© HACH LANGE GmbH, 2005. All rights reserved. Printed in Germany



Contents

Introduction	2	Programming USC 5000/6000/7000	15	Forced current and relay outputs	33
Mechanical Installation	4	Keypad and display layout	15	Service mode	33
Transmitter	4	Factory settings	16	Troubleshooting	34
Assembly	6	Menu structure	17	Error system	34
USC 5000/6000/7000	8	USC 7000 multidrop system.....	20	Troubleshooting guide - TSS 4100 transmitter	36
USC 6000/7000 19" version	9	Setting of turbidity/suspended solids units	21	Troubleshooting guide - USC	38
Optional add-on module USC 6000/7000	10	USC 5000/6000 current output settings	22	Technical Data	41
Optional add-on module USC 6000/7000 19" version.....	11	USC 7000 current output settings	23	Transmitter	41
Electrical installation	12	USC 6000 relay output settings.....	24	USC	42
USC 5000/6000 and TSS 4100 point to point	12	USC 7000 relay output settings.....	25	HART®	44
USC 7000 and TSS 4100 multidrop	13	Calibration	26	Warranty, liability and complaints	45
Initial start up	14	Suspended solids only	26	Contacts	46
System with USC 5000/6000/7000	14	Maintenance	28		
		Other Settings	29		
		Operator menu setup	29		
		System information	30		
		Transmitter information.....	30		
		USC information	30		
		Reset mode	31		
		Send command	31		
		Advanced settings	32		

Introduction



TSS 4100 transmitter

The EVITA® TSS can be applied to all applications where turbidity or suspended solids measurement is required. Ranging from measurement in activated sludge, to controlling surplus sludge removal and sludge recirculation. The transmitter can also be utilised to measure and control sludge feed and polymer dosing to centrifuges and belt presses.

EVITA® TSS consists of a TSS 4100 transmitter - with or without wiper - and a USC Universal Signal Converter.

There are two versions of the transmitter – one for pipe mounting using the Tri-Clamp® system and one with threaded design for mounting in a basin. The operating principle is identical for both versions.

There are three versions of the USC - a USC 5000 basic version, and a USC 6000 with added features, both point to point. A USC 7000 with HART® multidrop functionality enabling up to 15 transmitters on only two wires.

The EVITA® TSS 4100 transmitter has two LED light sources and four emitter diodes. Taking several measurements with all diodes provides a reading which has been compensated for any errors due to fouling, aging of the light sources or diodes, or scratching of the lenses.



USC 5000 IP 67 (NEMA 4X)



USC 6000/7000 IP 67 (NEMA 4X)



USC 6000/7000 19"



Documentation needs to be consulted.



The user shall be made aware of that, if the equipment is used in a manner not specified by the manufacturer, the protection provided by the equipment may be impaired.



The EVITA® TSS system offers several advantages:

Digital HART® transmitter

- simple and fast installation

Easy maintenance

- high quality probe material
- highly polished sensor surface
- automatic self-cleaning system available for very harsh applications

High reliability

- self-diagnosing
- air bobble system removing the typical noise in signal
- multi angle detection and advanced algorithm

Flexible communication

- HART® communication as standard gives added features
 - setting of measuring range and units from a distance
 - display of turbidity, suspended solids and specific event codes
- Option module can be fitted in the USC 6000/7000 without the need for tools



Mechanical Installation

Transmitter

The mounting bracket for the TSS 4100 transmitter can be mounted directly on to a concrete wall using 2 bolts AISI 316 (diameter max. 10 mm or 3/8 UN).

The mounting bracket can be mounted either on the top (fig. 1) or on the inside of the basin wall (fig. 2).

Use a screwdriver to lock the mounting bracket in position, so the PVC pipe is located vertically.

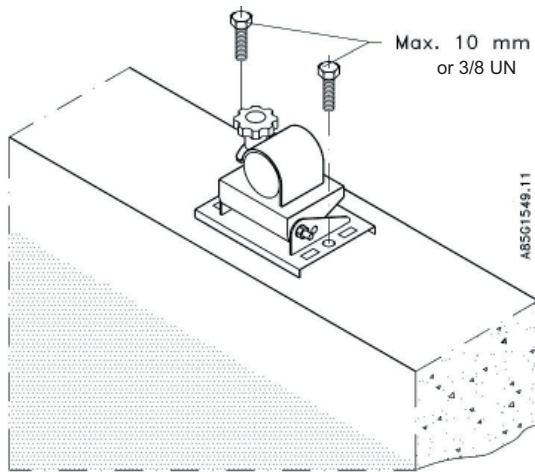

Fig. 1

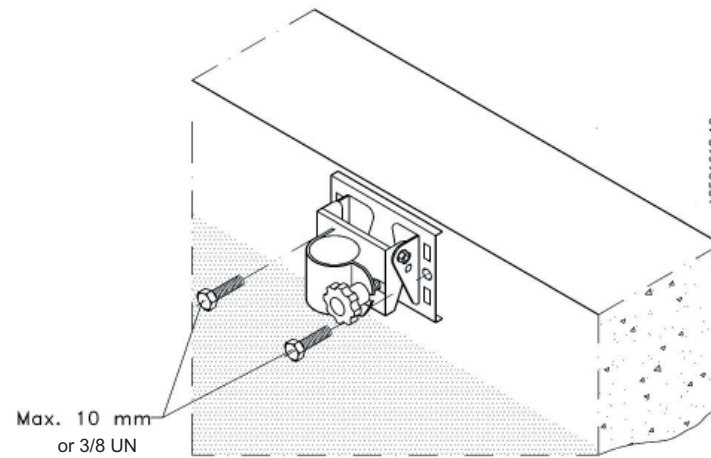

Fig. 2

In case of strong sideways forces, use a stainless steel pipe.

When using a 45° or a 90° elbow, rotate the PVC pipe, so the transmitter points in the flow direction, see fig. 4.

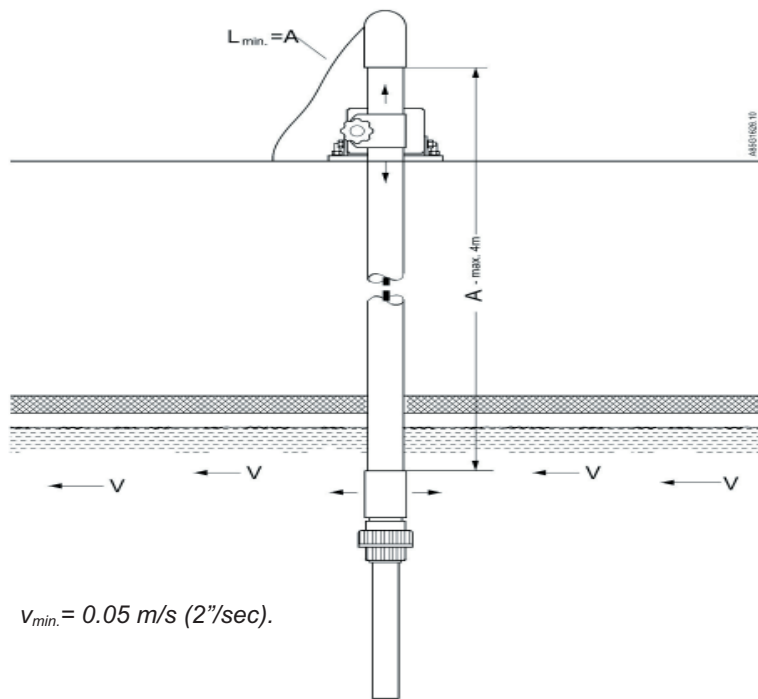

Fig. 3

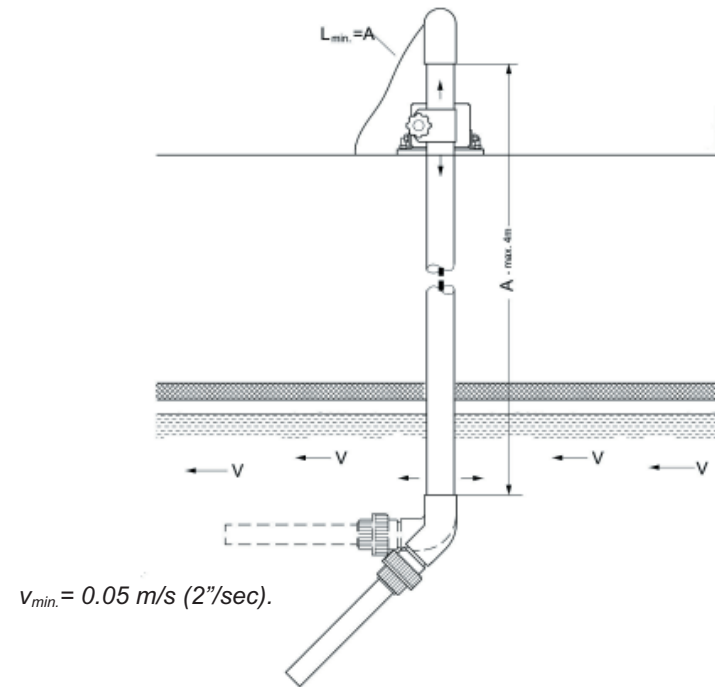

Fig. 4

Assembly

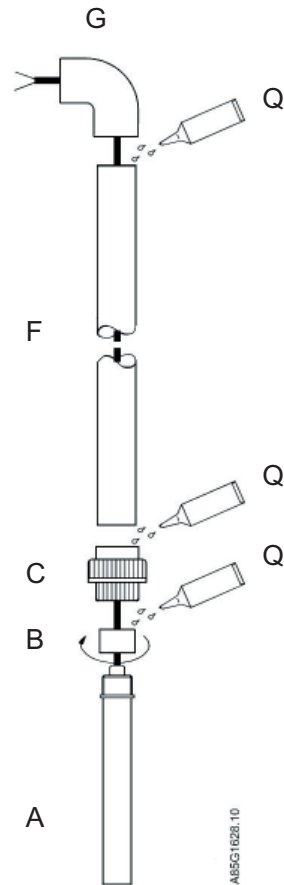

Fig. 5

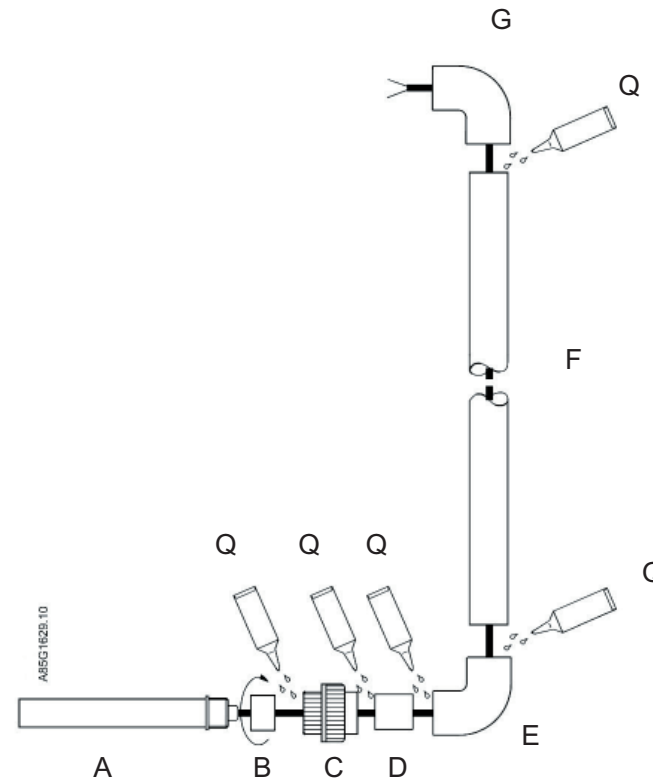

Fig. 6

Mount the single parts as shown in fig. 5 or fig. 6.

A: TSS 4100; 1 1/4" pipe thread

B: Connection pipe, inside 1 1/4" thread, outside diameter 50 mm; is supplied with transmitter

C: Connector, inside diameter 50 mm; supplied by the customer

D: PVC or ABS pipe, outside diameter 50 mm, length 60 mm; supplied by the customer
(For USA: part number 085G2373)

E: 45° or 90° PVC or ABS elbow; inside diameter: 50 mm or 1 1/2"; supplied by the customer

F: PVC or ABS tube; 50 mm or 1 1/2"; supplied by the customer

G: 90° PVC or ABS elbow; inside diameter: 50 mm or 1 1/2"; supplied by the customer

Q: PVC or ABS adhesive; supplied by the customer

Optional power supply/connection box

The EVITA® TSS transmitter is operating on 20-28 V d.c. An optional power supply and connection box is available to convert from mains voltage (110-240 V a.c.) to 24 V d.c.

The optional power supply/connection box needs to be located close to the mounting bracket as the cable length of the TSS 4100 transmitter is 5 m.

Note: A TSS 4100 transmitter connected to a USC 5000/6000 can work without the optional power supply installed.



A suitable power supply shall be considered in the end-use application. The power supply must be a Class 2 power source (limited circuit) according to the National Electrical Code (NEC) and provided double/reinforced insulation between mains and the 24 V d.c. supply for the TSS transmitter.

USC 5000/6000/7000

Mounting on handrail

Mount the bracket on a vertical or horizontal pipe using the two stainless steel hose clips.

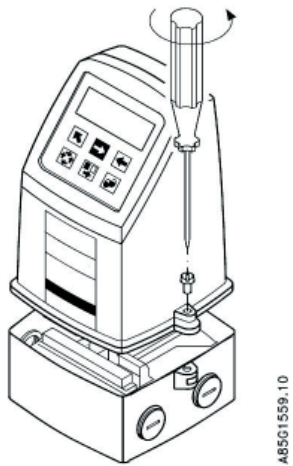

AB501559.10

Fig. 7

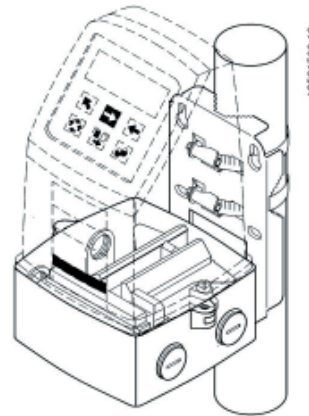

AB501560.10

Fig. 8

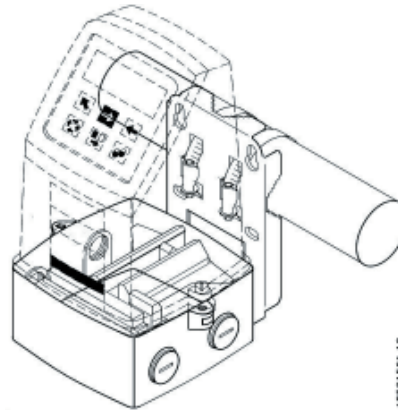

AB501561.10

Fig. 9

Mounting on concrete wall

Mount the bracket on a wall using four screws (diameter max. 8 mm or 5/16").

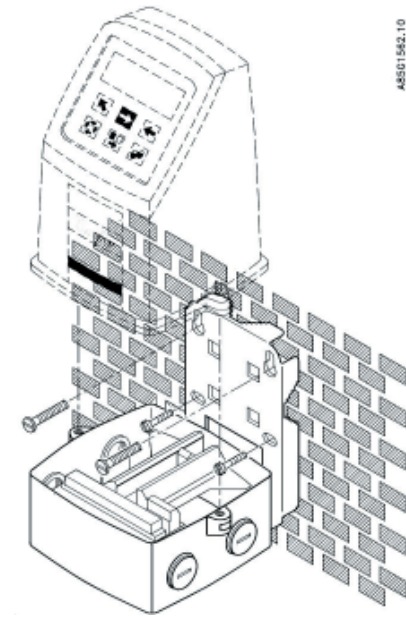

AB501562.10

Fig. 10

USC 6000/7000 19" version

Mounting in panel

First mount the terminal board in the front panel IP 65 (NEMA 4X) enclosure, figs. 11 and 12, or the back of the panel bracket, fig. 13. Plug in the 19" USC 6000/7000 signal converter in the enclosure or bracket using the four small screws to tighten it.

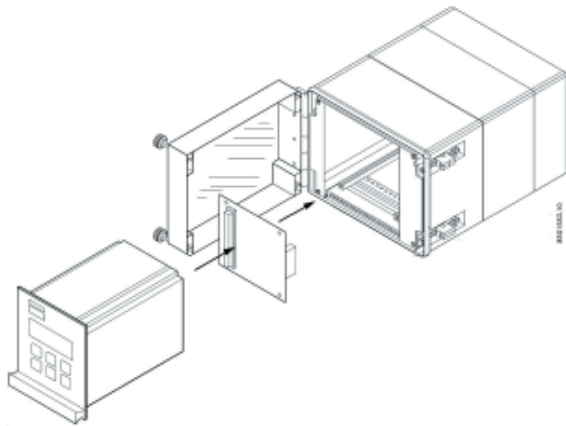

Fig. 11

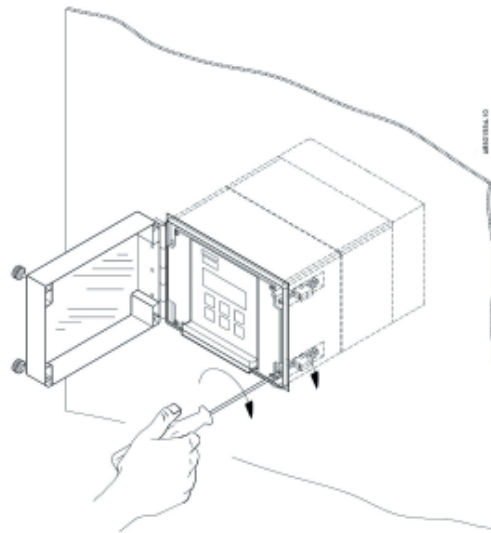

Fig. 12

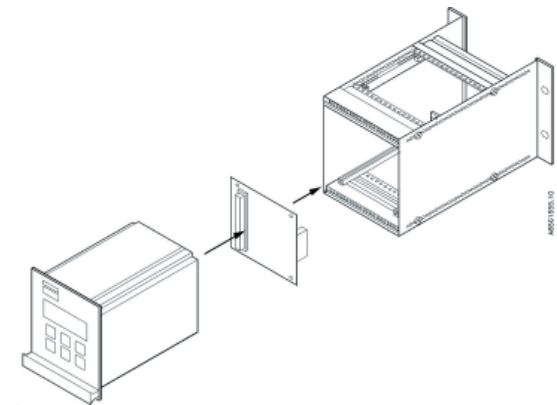

Fig. 13

Optional add-on module USC 6000/7000

Unpack the add-on module and locate it in the bottom of the signal converter as shown in fig. 14.

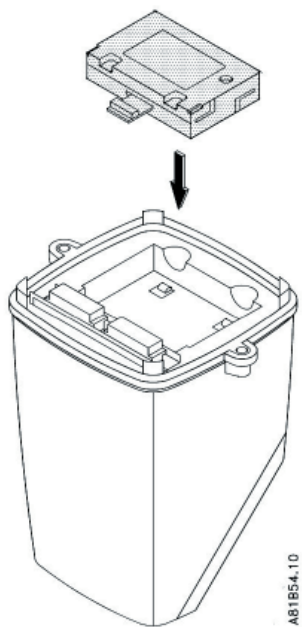

Fig. 14

Press the add-on module forward as far as possible. See fig. 15. Avoid touching the pc board and the sockets.

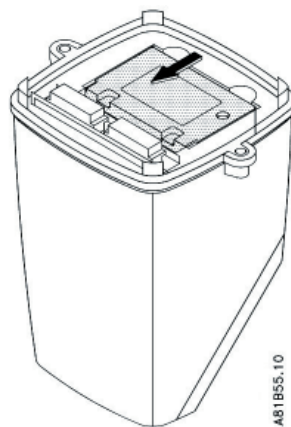

Fig. 15

The add-on module has now been installed and the signal converter is ready to be installed on the terminal box. Communication to the operator menu and electrical inputs and outputs are automatically established by power on.

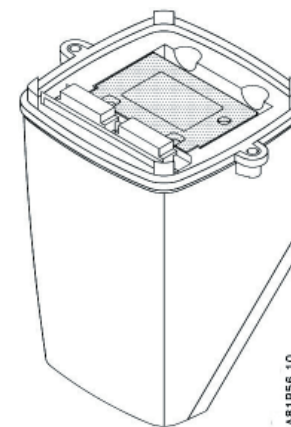

Fig. 16

Optional add-on module USC 6000/7000 19" version

Unpack the add-on module and locate it in the bottom of the signal converter as shown in fig. 17.

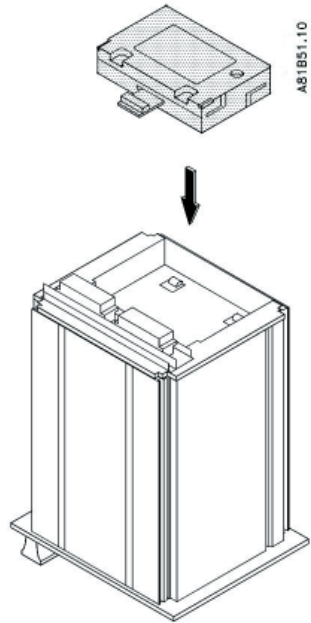

Fig. 17

Press the add-on module forward as far as possible. See fig. 18. Avoid touching the pc board and the sockets.

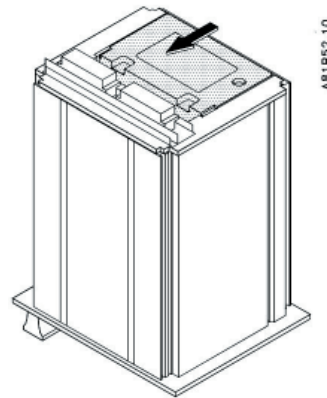

Fig. 18

The add-on module has now been installed and the signal converter is ready to be installed on the terminal box. Communication to the operator menu and electrical inputs and outputs are automatically established by power on.

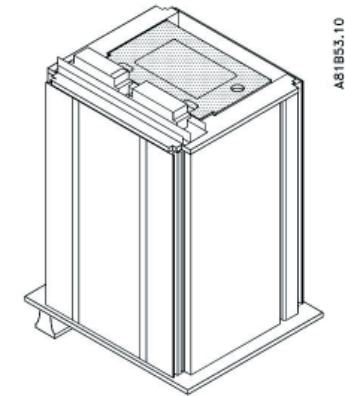

Fig. 19

Electrical installation

USC 5000/6000 and TSS 4100 point to point

The EVITA® TSS 4100 transmitter is connected using the four-wire, shielded cable. Two leads carry supply voltage and the other two leads carry HART® communication.

Depending on the USC version the power supply should be connected to terminals L, N and PE when using 110-240 V a.c., or to terminals 1 and 2 when using 24 V a.c./d.c., see fig. 20 and fig. 21.

If the cable is extended, the total length of the cable must not exceed 1000 m (3000'). Always use four-wire, shielded cable for the extension (min. 4 x 0.34 mm² (22 AWG)). Extension of the cable causes a voltage drop across the extended cable. Always ensure a minimum of 20 V d.c. is supplied to the transmitter.

On the USC signal converter it is possible to disable the function of the digital input (used for calibration control on the EVITA® INSITU 4100 transmitter).

Note: The digital input is available on both USC 5000, USC 6000 and USC 7000.

USC 5000/6000 - IP 67 version

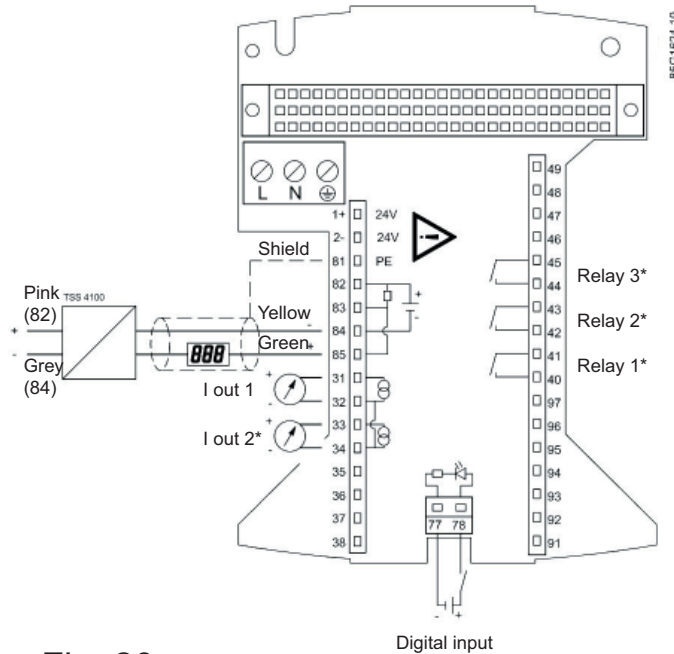

Fig. 20

*Only USC 6000

USC 6000 - 19" version

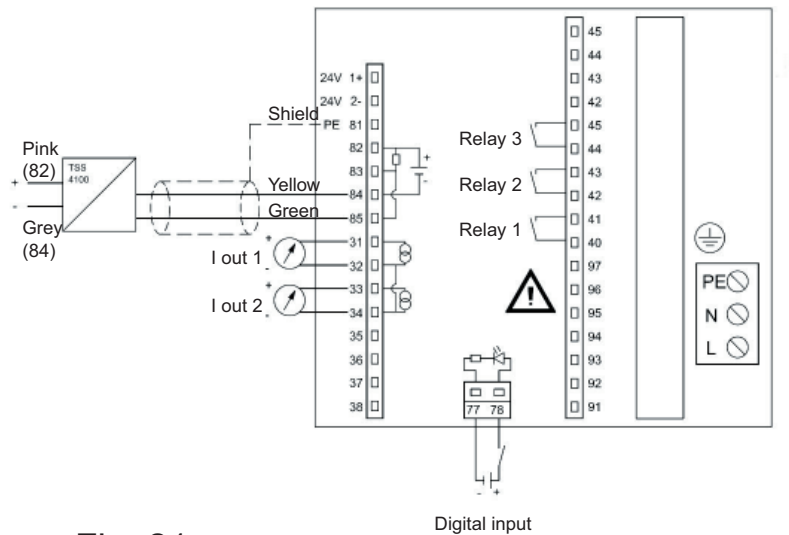
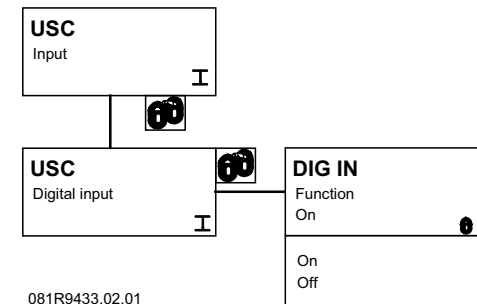

Fig. 21



081R9433.02.01

Fig. 22

USC 7000 and TSS 4100 multidrop

The USC 7000 is able to communicate with up to 15 EVITA® transmitters using HART® multidrop protocol on two wires.

Each transmitter should be connected in parallel outside the USC connection box and only two wires with shield mounted on the terminals in the USC 7000.

Due to limited internal power supply in the USC 7000 signal converter, the TSS 4100 transmitters must be connected to optional power supplies, see p. 7.

Because the TSS 4100 transmitter has no galvanic isolation, each TSS 4100 transmitter in a multidrop system must be supplied separately (connected to separate power supplies).

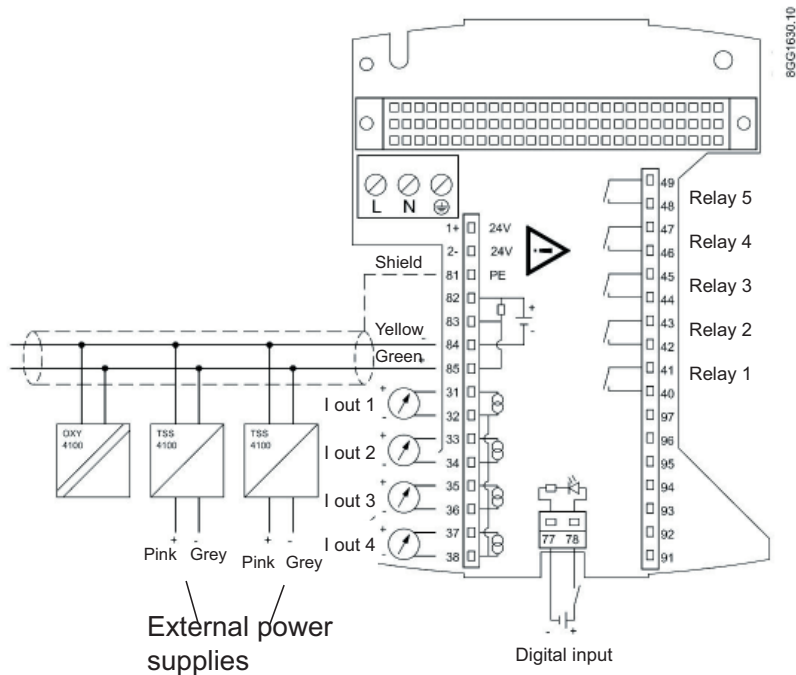





Fig. 23

Important: The below mentioned warnings concern both USC 5000, USC 6000 and USC 7000.

 The HART® communication terminals (84/85) and the Digital Input terminals (77/78) of the Universal Signal Converter must not be connected to external voltage level above 30 V d.c.

 The Relay terminals (40-49) of the Universal Signal Converter must not be connected to external voltage level exceeding 48 V d.c., 30 V rms or 42 V peak.

 Protective conductor terminal. Required cable min. AWG16 or 1.5 mm² Cu.

 Field wiring installation of the Universal Signal Converter must be in accordance with the National Electrical Code.

 Mains supply 100 to 240 V a.c. from building installation (Overvoltage category II). A switch or circuit-breaker (max. 15 A) shall be included in the building installation. The switch/circuit-breaker shall comply with relevant requirements of IEC 947-1 and 947-3. It must be in close proximity to the equipment and within easy reach of the operator, and it shall be marked as the disconnecting device for the equipment.

Note: Components like motors, pumps and computers may cause high voltage potential differences between the protective earth/ground wire and the water in the tank, that results in unstable readings. If this problem occurs, mount an earthing electrode in the tank to equalise the electrical potential of the water to PE. If the flow velocity in the tank is high, it may cause a static potential locally. If this is the case, mount the earthing electrode close to the transmitter.

Initial start up

System with USC 5000/6000/7000

Measuring turbidity

1. Place the transmitter in the media.
2. Turn on the power to the signal converter USC 5000/6000/7000.
3. Choose language, see paragraph “Important” p. 16.
4. Check factory settings of unit and range, see p. 17. Change if necessary.

Measuring suspended solids

1. Place the transmitter in the media.
2. Turn on the power to the signal converter USC 5000/6000/7000.
3. Choose language, see paragraph “Important” p. 16.
4. Change sensor type to “Suspended solids” in “Advanced settings”, see p. 33.
5. Set “Suppress errors” to “Turbidity”, see p. 33.
6. The error ET52 - Calibration error - will show until a proper calibration has been performed.
7. Select units and set measuring range in “Basic settings”, see p. 21.
8. Calibrate in accordance with the instructions in the “Calibration” section, p. 26.





Programming USC 5000/6000/7000

Keypad and display layout









Fig. 24



Various display symbols

-  Ready for change
-  Value locked
-  Access to submenu
-  Confirmation of choice



The keypad is used to set the EVITA® TSS and to step through the menus. The function of the keys are as follows:

TOP UP KEY (ESC)		This key (hold for 2 sec.) is used to switch between the operator menu and the setup menu, see p. 18-19. A short press will cause a return to the overlying menu.
FORWARD KEY		This key is used to step forward through the menus in the setup menu.
BACKWARD KEY		This key is used to step backward through the menus.
CHANGE KEY		This key changes the settings or numerical values in the setup menu. In the operator menu it is used to step through the menus.
SELECT KEY		This key selects which digits to be changed.
LOCK/UNLOCK KEY (ENTER)		This key allows the operator to change settings and gives access to submenus.

IMPORTANT:

The USC starts up showing the menu “Language” in English. Press the  key until the wanted language appears in the display and press the  key. After the language is chosen, the USC will show “Turbidity” in the operator menu (see p. 18).

The factory setting of the language can be re-established as follows:

- Switch off the power supply
- Press the  key and switch on the power supply
- Release the  key after 10 seconds

The language is now reset to English.

Factory settings

The EVITA® TSS system is supplied with the following factory settings:

	Parameter	Factory settings	Options	Page
USC 5000/6000/7000	Current output 1 (System packages 1 and 2)	0-4000 FNU	Range: min. 0 FNU max. 9999 FNU Span: min. 100 FNU	22
	Current output 2 (System package 1)	0-400 g/l	Range: min. 0 g/l max. 400 g/l Span: min. 10 g/l	22
	Current outputs USC 5000/6000/7000	OFF	OFF ON	22-23
	Relays 1, 2 and 3 (USC 6000)	OFF	Alarm; Warning; Limit; Timer; OFF	24
	Relays 1, 2, 3, 4 and 5 (USC 7000)	OFF	Alarm; Warning; Limit; Timer; OFF	25
	Current output when not measuring	Hold	High; Low; Hold (last measured value)	22-23
	Current output during error	Normal	High; Low; Normal	22-23
	Password	1000	1000-9999	19
TSS 4100	Turbidity unit	FNU	FNU; NTU; EBC	21
	Suspended solids unit	g/l	g/l; mg/l; ppm; %	21
	Time constant	40 sec.	5-9999 sec.	33
	Sensor type	Turbidity	Turbidity; Suspended solids	33
	Suppress errors	Suspended solids	No suppression; Turbidity; Suspended solids	33

Menu structure

The menu of the signal converter is built up in two parts. An **operator menu** and a **setup menu**.

Operator menu

The operator menu is for daily use. After any programming or viewing of the settings, the signal converter will return to the operator menu, showing either “Turbidity” or “Suspended solids” depending on the selected sensor type.

The USC 5000/6000 is point-to-point installation while the USC 7000 is for a multidrop system. In fig. 25-26 menus marked with grey are only visible in the multidrop system. It is possible to hide some of the menus in the operator menu, see fig. 35, p. 30.

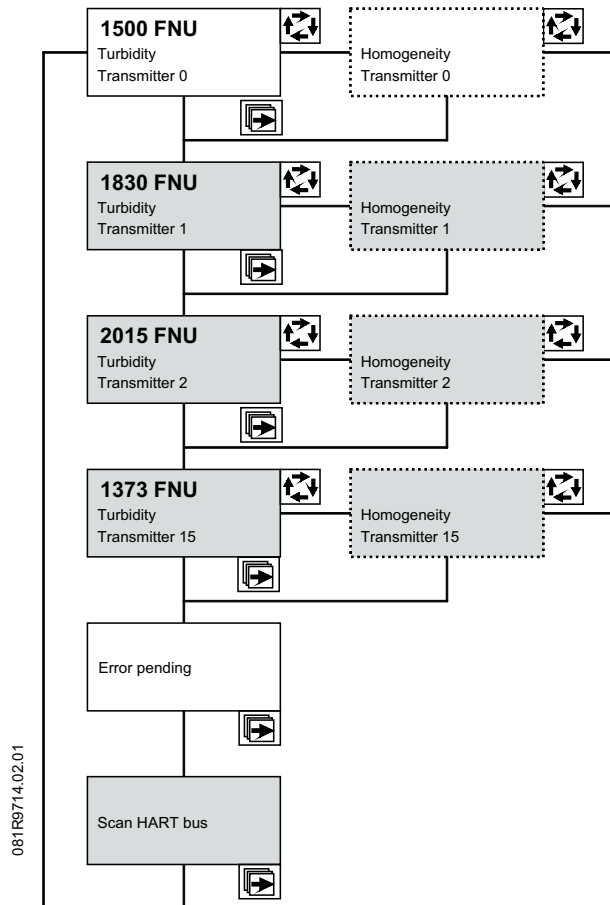

Fig. 25

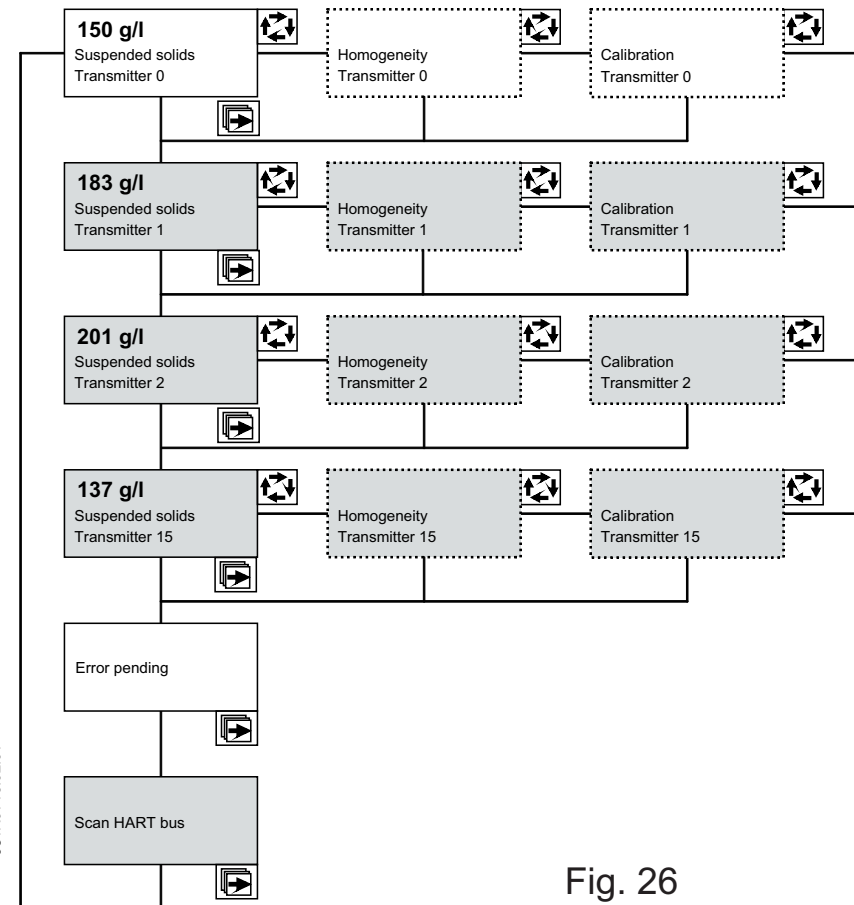



Fig. 26



Setup menu

The setup menu is shown in an overview diagram (fig. 27) on page 19.

The setup menu consists of two parts:



- USC setup menu - for USC settings
- Transmitter setup menu - for transmitter settings

The setup menu is for commissioning and service and for changing the settings. Access to the setup menu is gained by pressing the  key for 2 seconds. The setup menu will operate in two modes:

• **View mode** is a read only mode. The preselected settings can only be scanned. The view mode is accessed by pressing the  key for 2 seconds. Instead of keying in the password, press the  key.

• **Setup mode** is a read and write mode. The pre-selected settings can be scanned and changed. The setup menu is accessed by pressing the  key for 2 seconds and entering the password. The factory set password is 1000, but can be changed to any value between 1000 and 9999.

The factory setting of the password can be re-established as follows:

- Switch off the power supply
- Press the  key and switch on the power supply
- Release the  key after 10 seconds

The password is now reset to 1000.

Fig. 27

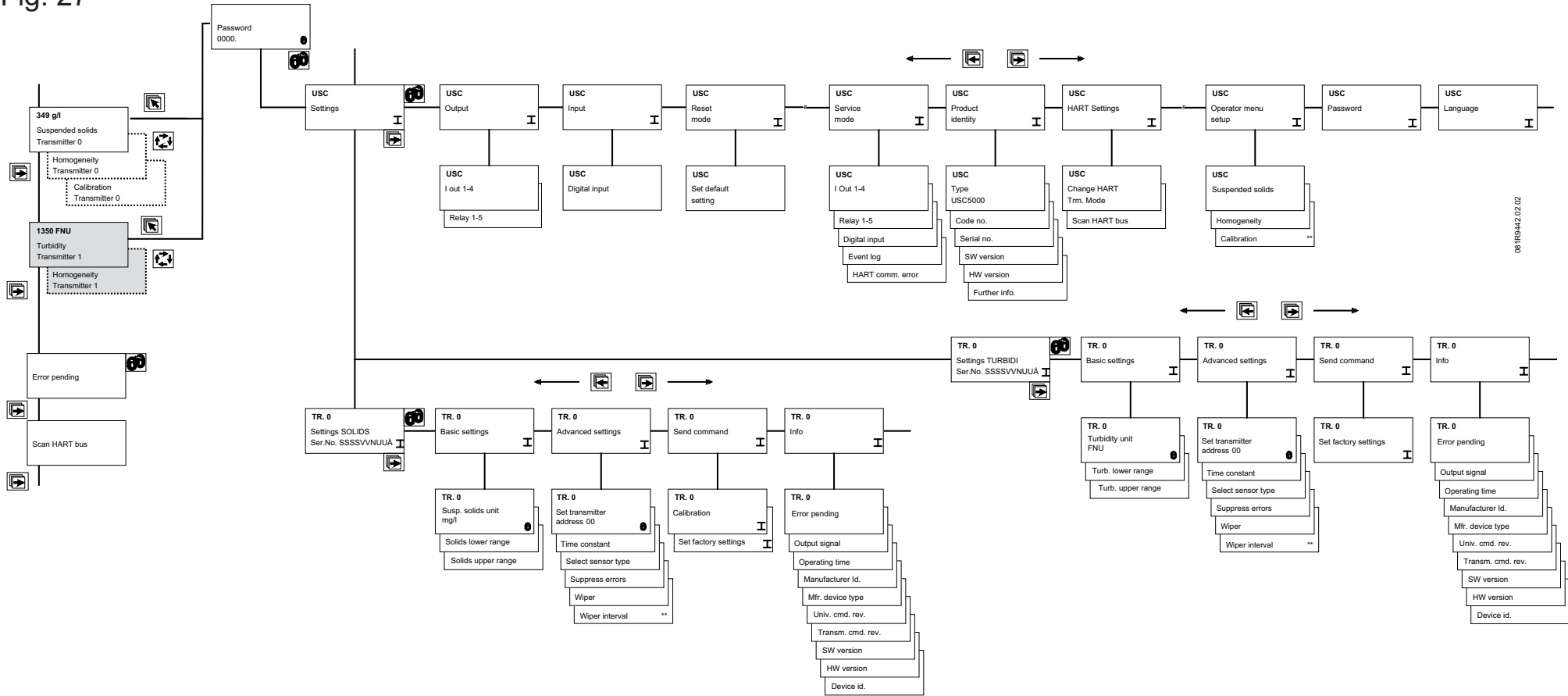

USC 7000 multidrop system

Change transmitter address from default

To allow the USC 7000 to recognise the transmitter on the HART® bus, the transmitter needs a unique address between 1 and 15. The EVITA® TSS transmitter is factory delivered with the address 0, which is used for point-to-point installations (USC 5000/6000).

To programme the address of a new transmitter, connect the transmitter to the USC 7000 and press “Scan HART bus”. The transmitter will get the next available address between 1 and 15.

Note: If, before scanning the HART® bus, a TSS 4100 transmitter with address higher than 0 was registered as interrupted (disconnected for at least 2 min.), the new TSS 4100 transmitter will be assigned this address.

* Menu not visible when turbidity

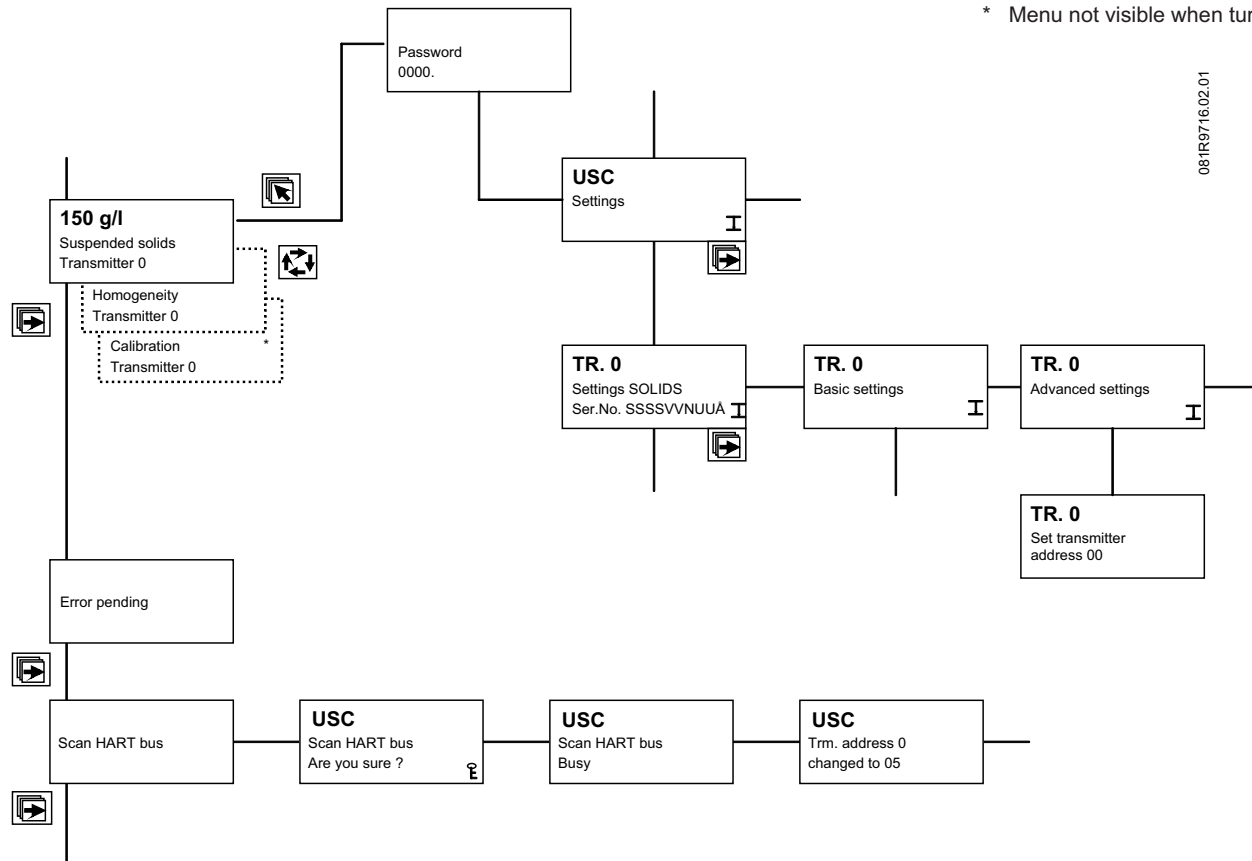

Fig. 28

Setting of turbidity/suspended solids units

If other settings are wanted, the factory settings can be changed as shown below.

Setting of the units and ranges for turbidity and suspended solids can be done in "Basic settings".

However the setting of the USC current outputs range for turbidity and suspended solids is done as shown in fig. 30, p. 22 and fig. 31, p. 23.

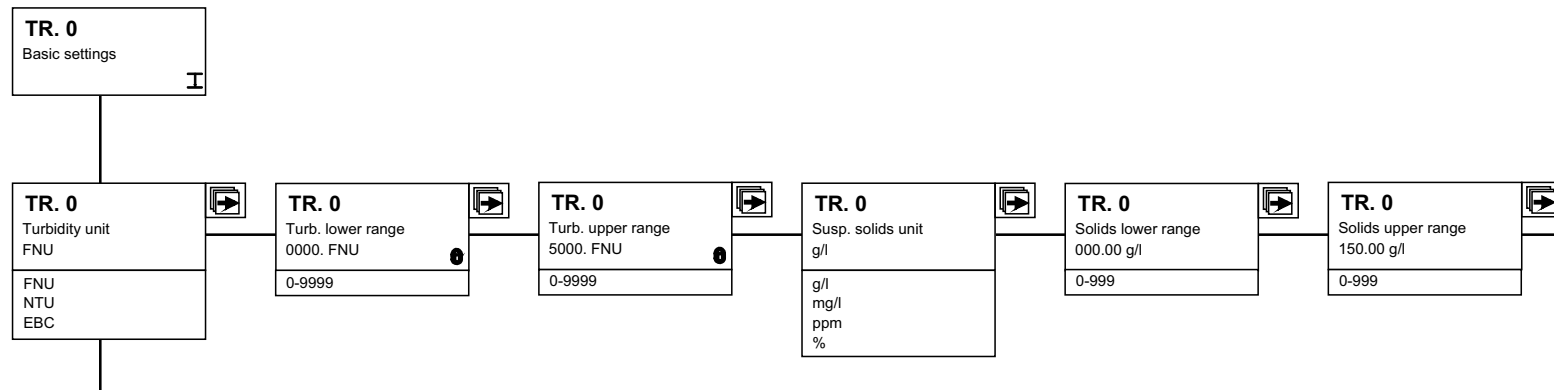

081R970.1.02.01

Fig. 29

USC 5000/6000 current output settings

Setting of current output 1 on USC 5000 and current outputs 1 and 2 on USC 6000.

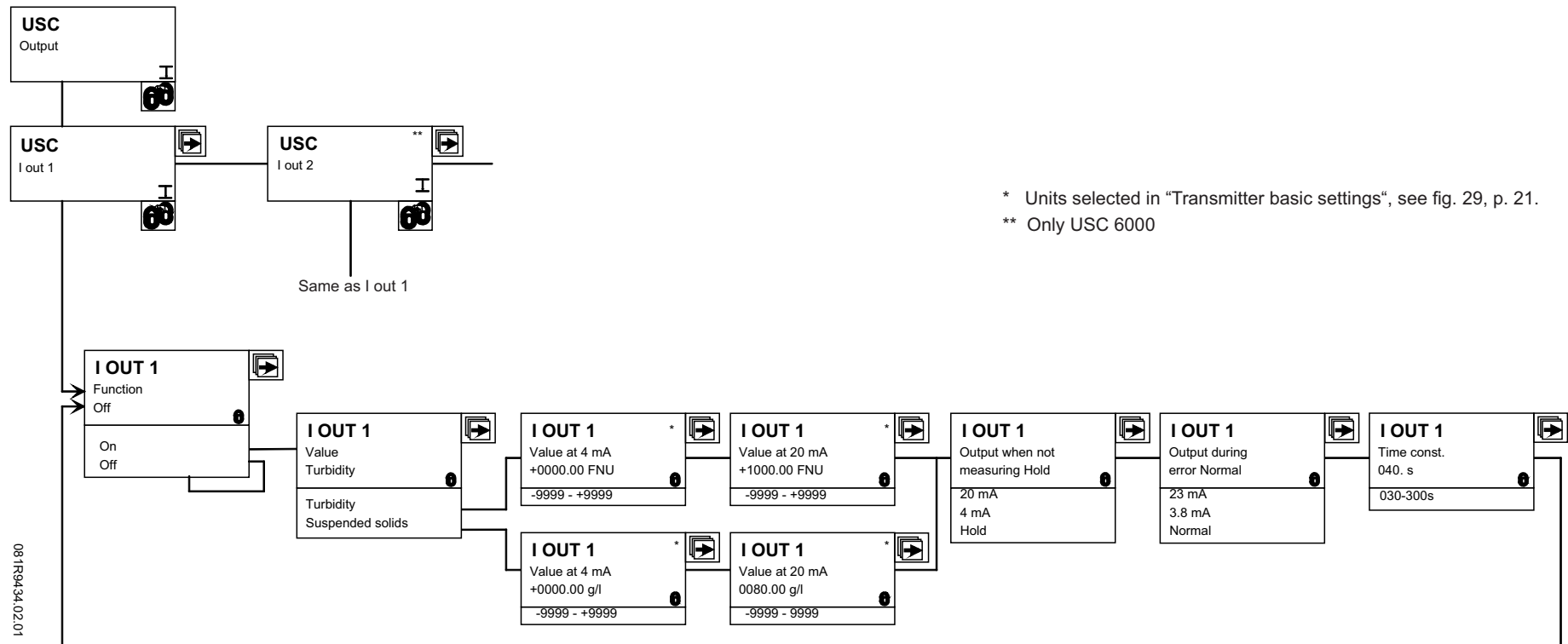

* Units selected in "Transmitter basic settings", see fig. 29, p. 21.
 ** Only USC 6000

Fig. 30

USC 7000 current output settings

Setting of current outputs 1 through 4 on USC 7000.

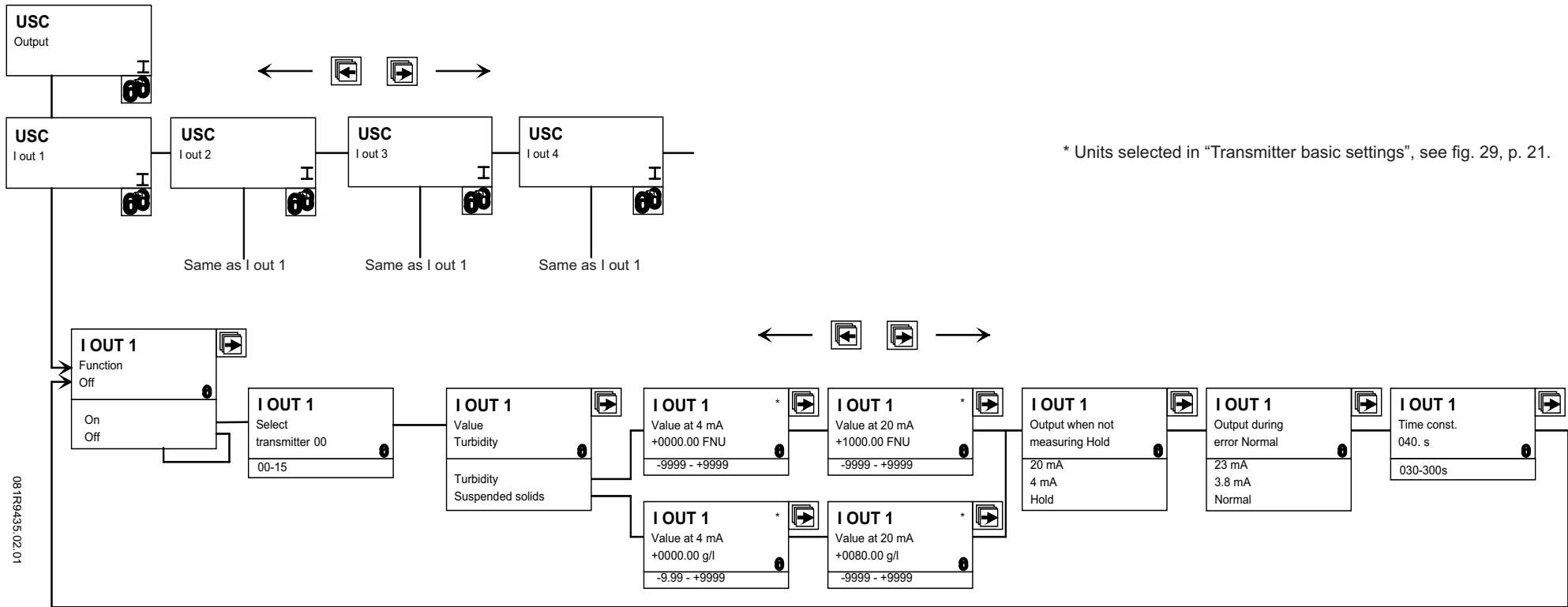

Fig. 31

USC 6000 relay output settings

Setting of relay outputs 1 through 3 on USC 6000.

* Units selected in "Transmitter basic settings" fig. 29, p. 21

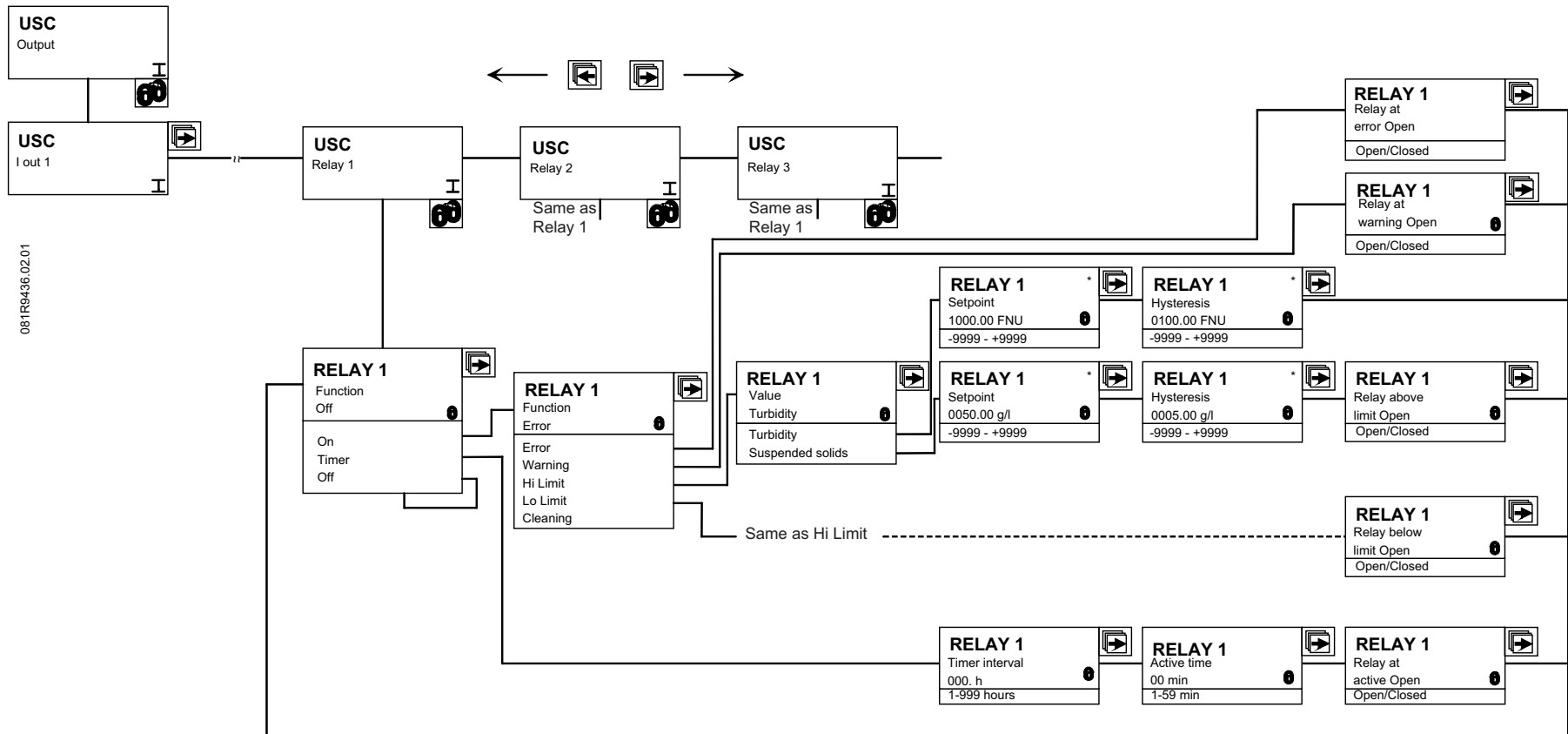

Fig. 32

USC 7000 relay output settings

Setting of relay outputs 1 through 5 on USC 7000

* Units selected in "Transmitter basic setting", fig. 29, p. 21.

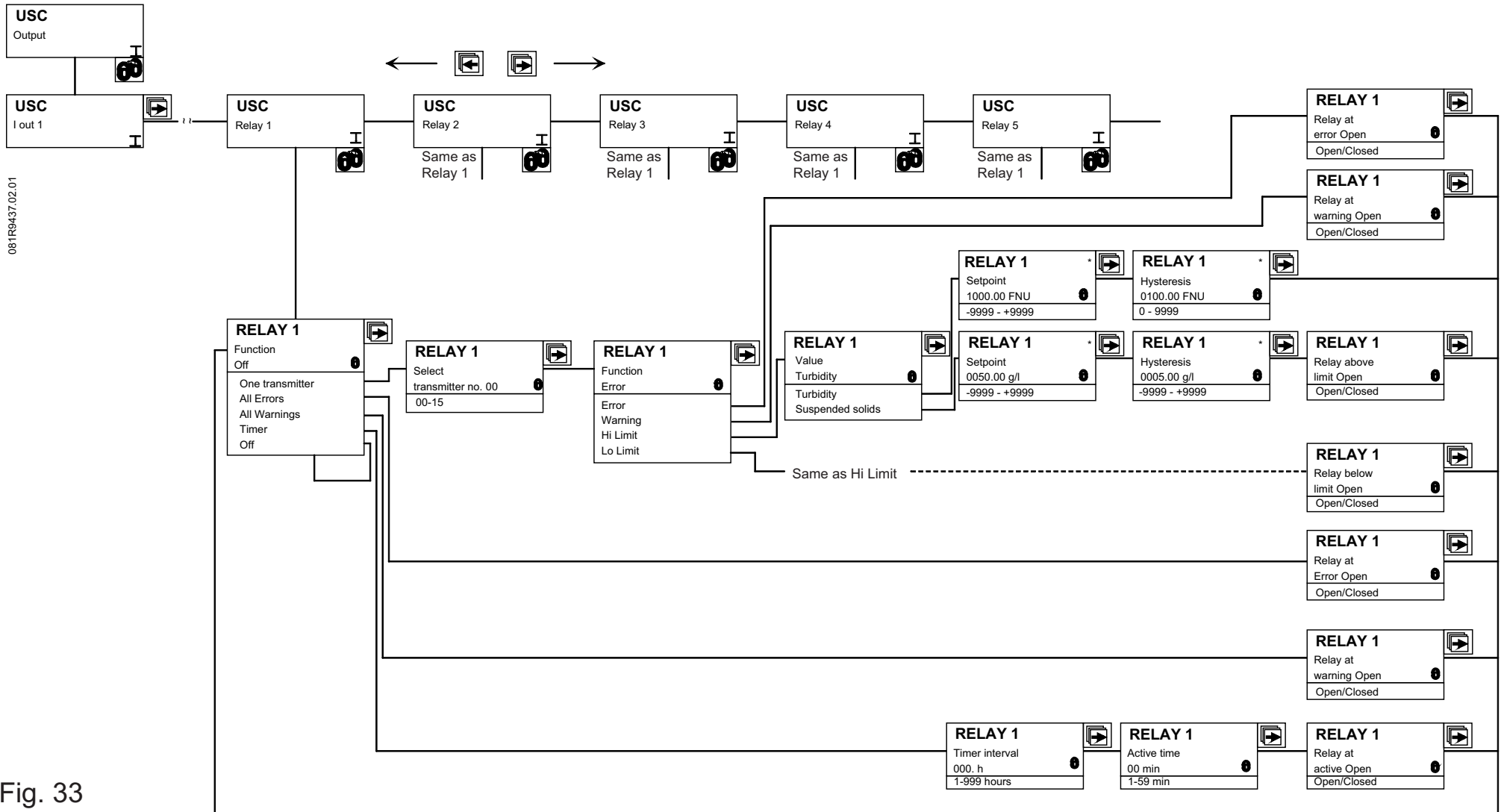

Fig. 33

Calibration

Suspended solids only

If the EVITA® TSS is used for measuring suspended solids a calibration has to be performed upon initial startup and periodically hereafter.

If the colour of the process changes significantly, the system must be recalibrated.

Calibration can be performed as a 1, 2 or 3 point calibration. Usually a 1 point calibration is sufficient.

1. Take out a sample.
2. Place the transmitter in the sample or leave it in the medium to be measured.
3. Go to “Measured values” in the “Calibration” menu on the USC signal converter and select calibration point 1, see fig. 34.
4. The USC signal converter will save the measured value.
5. If a 2 point or a 3 point calibration is to be performed, repeat steps 1 through 4 selecting calibration point 2 and 3 respectively in step 3.
6. Dry and weigh the samples to determine the concentration of suspended solids of each sample.
7. Go to “Reference values” in the “Calibration” menu on the USC signal converter and key in the concentrations found in step 6 for each calibration point.

After calibration has been completed, the calibration points will be sorted, so the lowest concentration is listed as calibration point 1.

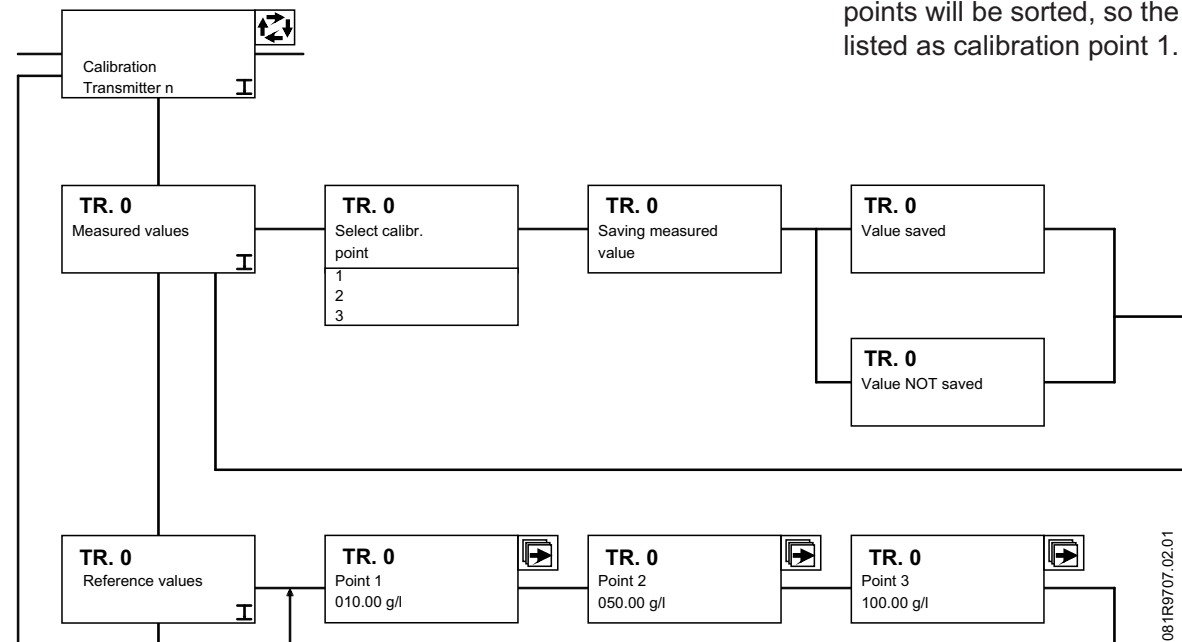
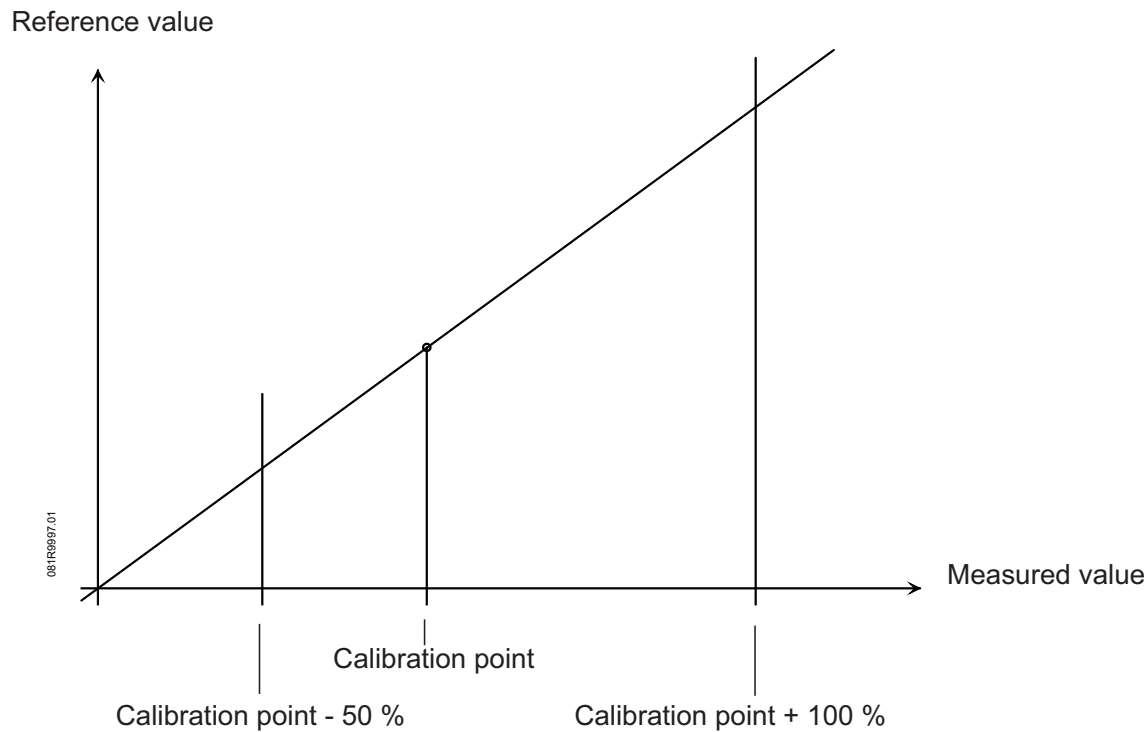

Fig. 34

If the measured value is below calibration point minus 50 % or above calibration point plus 100 %, calibration must be performed at a lower or a higher point respectively.



If a reference value for one of the calibration points is not keyed in, the transmitter will continue to measure with the old calibration values.

Note: Resetting of a calibration point can be done by entering 0 g/l as set point.

1. Go to the "Reference values" in the "Calibration" menu on the USC signal converter, see fig. 34.
2. Go to the point (1, 2 or 3) to be reset.
3. Key in 000.00 g/l as set point.

A calibration point with a reference value of 0 g/l will not be used to determine the calibration curve.

Maintenance

The EVITA® TSS 4100 transmitter needs to be cleaned regularly to maintain measurement accuracy. At first, clean the transmitter every 1-2 weeks until experience can determine the optimum time between cleanings.

Cleaning (transmitter)

Clean the transmitter using a soft moist cloth.

1. Lift the transmitter out of the medium.
2. Clean the sensor with pure water, to which a little cleaning agent/washing-up liquid can be added.
3. Dry the sensor with a soft cloth.
4. Immerse the transmitter into the medium to be measured.

Cleaning (signal converter)

When considered necessary, clean the USC signal converter using a soft moist cloth.

Replacement of wiper

A wiper kit consisting of 5 wipers is available.

1. Remove the defective/worn wiper.
2. Mount new wiper.

Other Settings

Operator menu setup

In the "Operator menu setup" it is possible to hide all menus except "Turbidity" / "Suspended solids" in the operator menu.

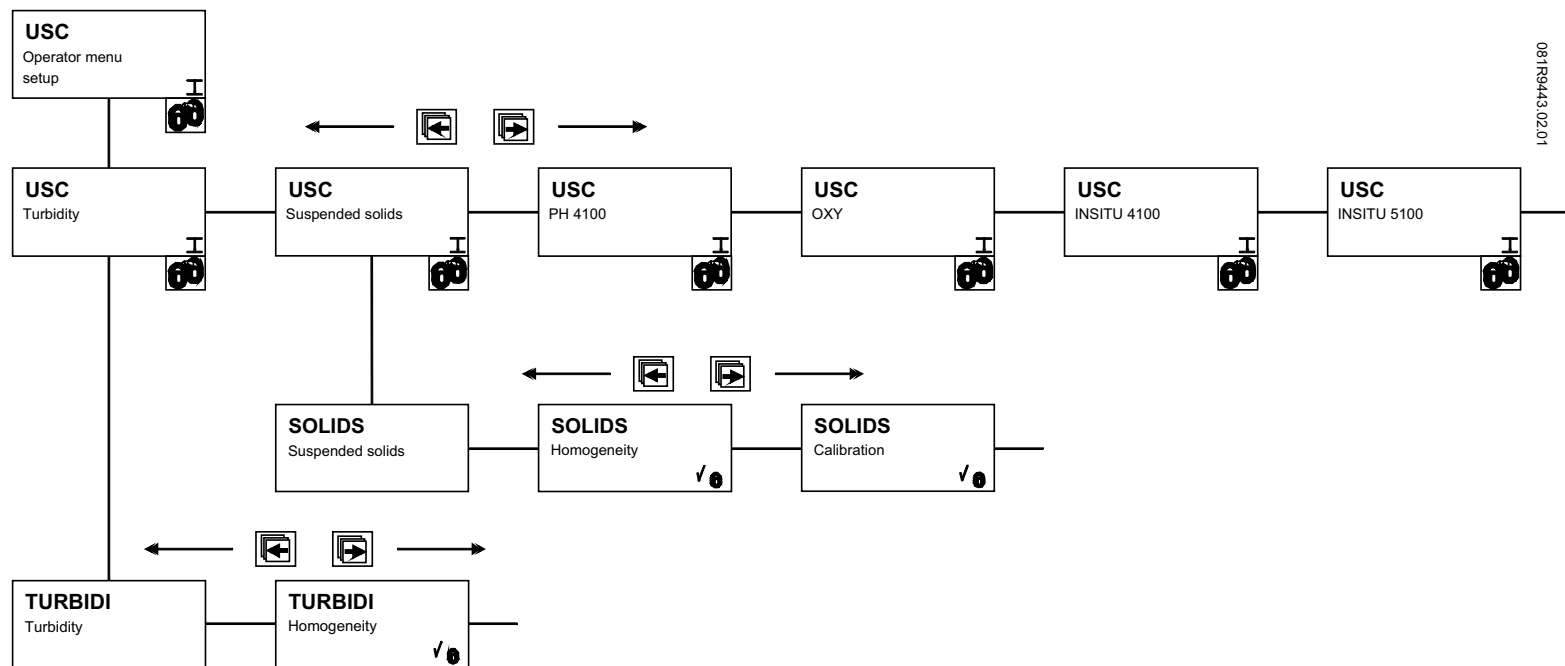

Fig. 35

- A ✓ in the operator menu setup means that this reading is shown in the operator menu.
- A ÷ in the operator menu setup means that this reading is not available when viewing the operator menu.

System information

Transmitter information

In the menu "Info" it is possible to view various information about the transmitter, e.g. output signal, operating time and software and hardware versions.

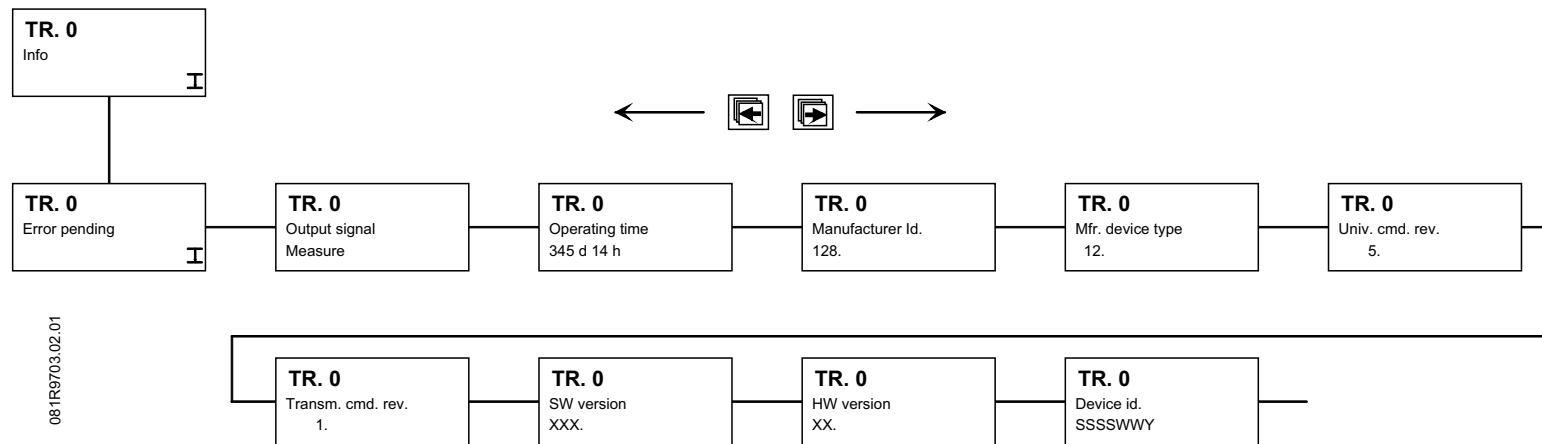

Fig. 36

081R9703.02.01

USC information

In the menu "Product identity" it is possible to read the USC type (5000/6000/7000) and the serial number.

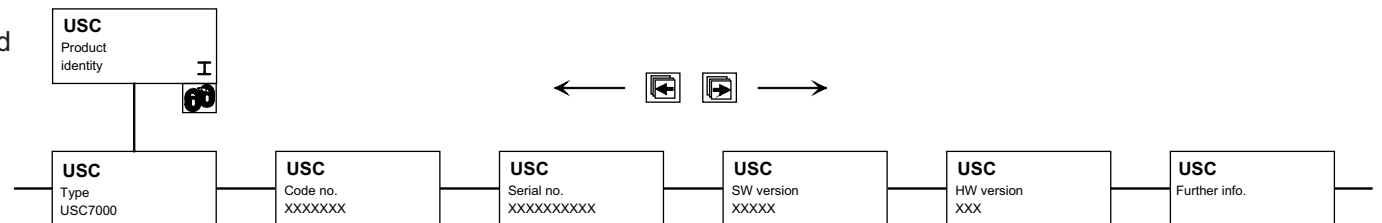

Fig. 37

081R9402.02.01

Reset mode

The factory settings for the USC signal converter can be re-established as shown in fig. 38.

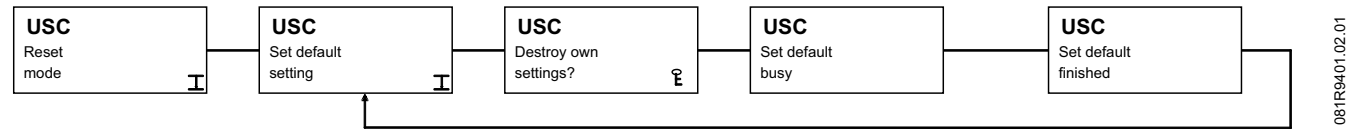

Fig. 38

Send command

In the "Send command" menu it is possible to start calibration and to set factory settings for the transmitter.

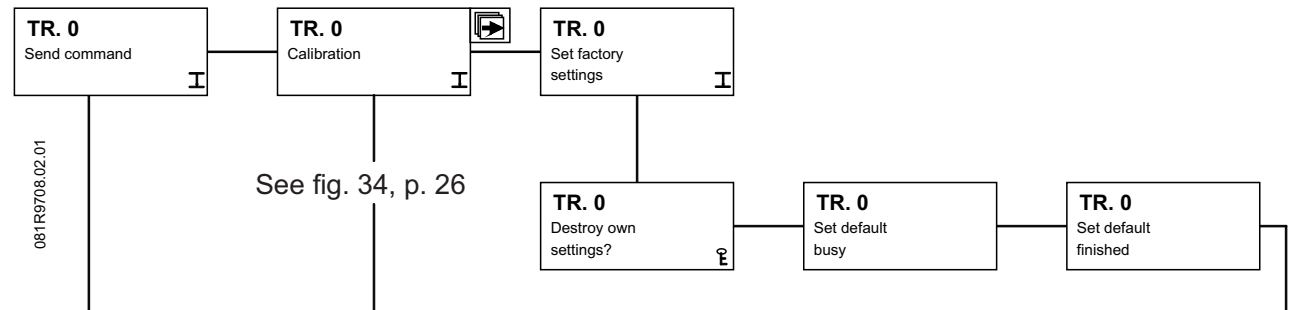

Fig. 39

Advanced settings

In the “Advanced settings” menu it is possible to select the sensor type and to set the wiper options. Also it is possible to select which errors, if any, to be suppressed.

Suppression of some of the errors means, that errors concerning the turbidity measurement are not shown, if the transmitter is measuring suspended solids and vice versa.

When operating in multidrop system using USC 7000, the transmitter must have a unique address between 1 and 15.

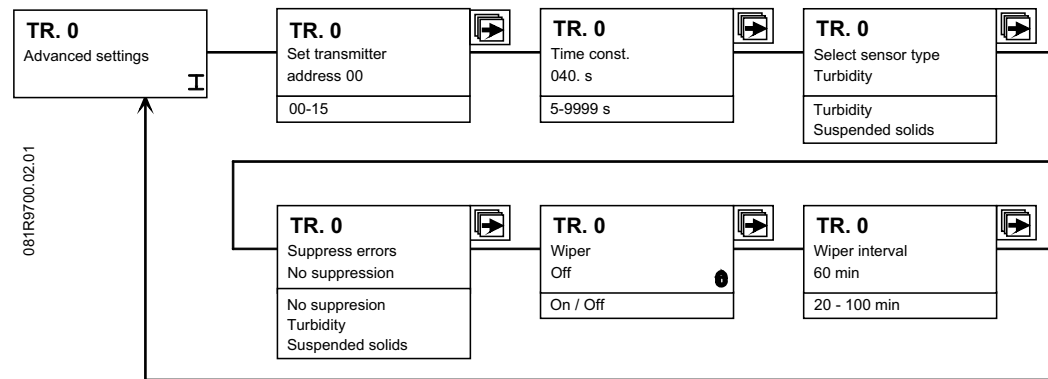
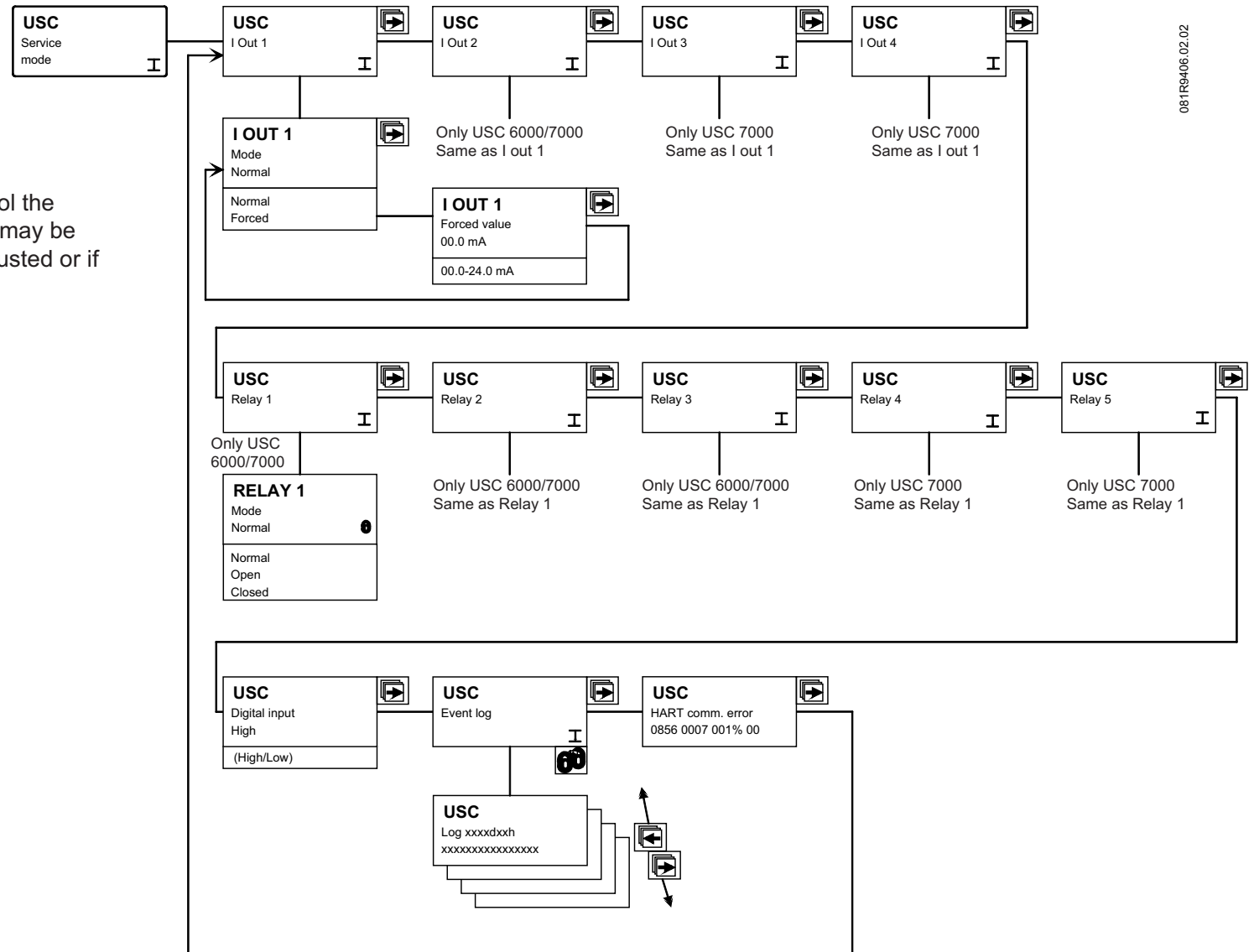

Fig. 40

Forced current and relay outputs

Service mode

In the "service mode" it is possible to control the relay and the current outputs directly. This may be useful when e.g. a control loop is to be adjusted or if an alarm signal should be checked.





081R9406.02.02

Fig. 41

Troubleshooting

Error system

The EVITA® TSS system has an advanced self-diagnostic system. If there is an error or a warning, a flashing bell  is displayed. To view the pending error information, press the  key in the operator menu – see below.

The USC has an 'event log' that stores past errors, information and warnings.

For a complete trouble shooting guide, see p. 36-40.

To access the USC event log, see fig. 41, p. 33.

Operator menu turbidity

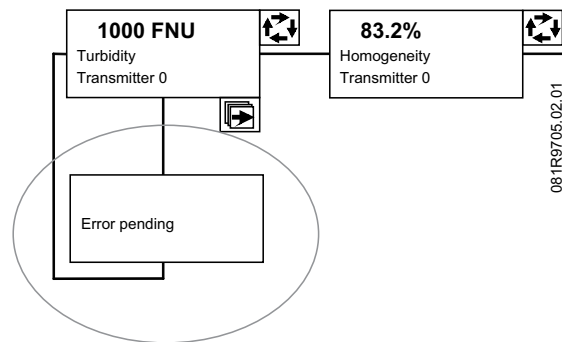

Fig. 42

Operator menu suspended solids

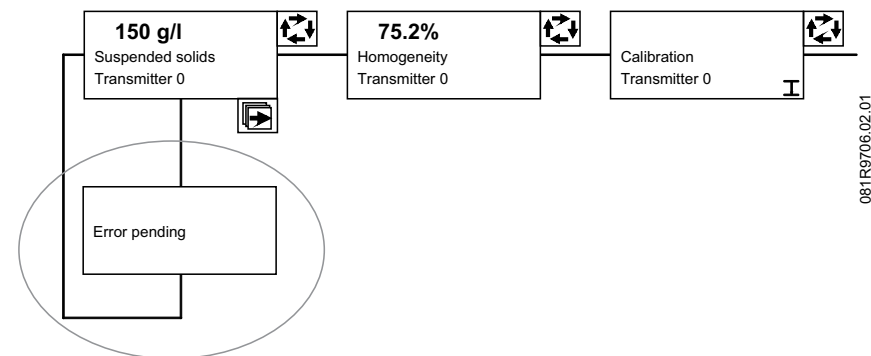
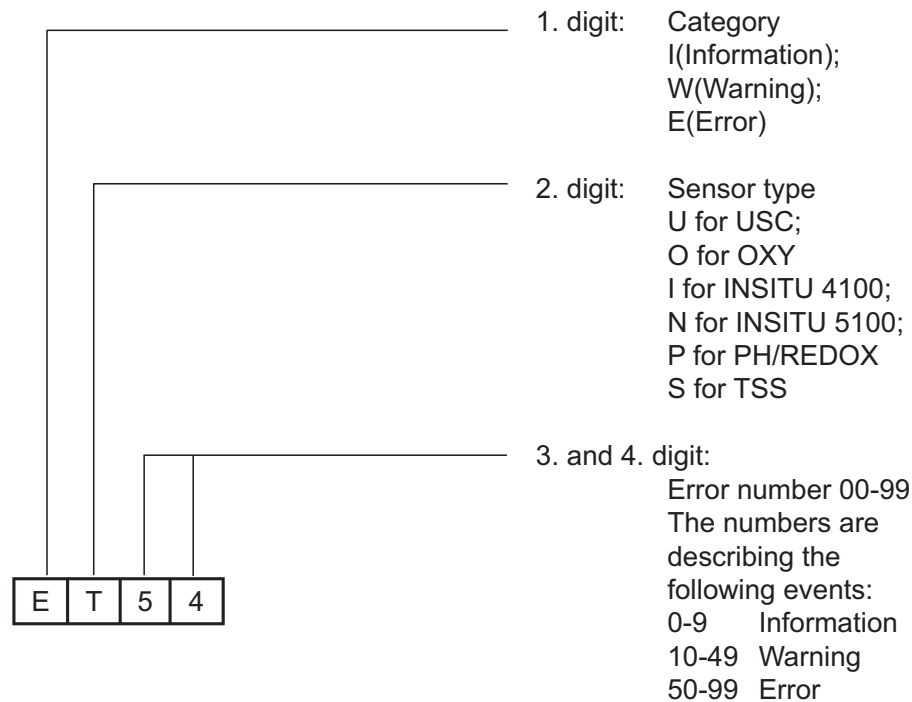

Fig. 43

Each event has an unambiguous identification consisting of 4 digits:



ET54: A software error occurred.

Information

The system will continue to measure as usual. Relay and output signals will not be affected.

Warning

The system will continue to measure, but there has been an event, which may cause malfunction of the system, and which may require an operator. The reason for the warning may disappear on its own. Warning relays, if defined, will show warning in accordance with the setup.

Error

The whole system or parts of it is malfunctioning, and the output signal is not reliable anymore. The errors require an operator. Error relays, if defined, will show error in accordance with the setup.

The EVITA® TSS transmitter error pending list shows the 8 latest occurred errors that are still pending.

The USC signal converter error pending list can show up to 14 pending errors and warnings, displayed with the USC errors first and then the transmitter errors. If there are more than 14 pending errors, the message “Additional errors cannot be viewed” will show in the display. The USC event log shows the 9 latest events.

Troubleshooting guide - TSS 4100 transmitter

Symptom	Event code	Cause	Remedy
Error in measuring value	None	Calibration value incorrect	Perform calibration, see p. 26
None	IS02	The measured value has exceeded 4000 FNU	Information
Constant measuring value	IS03	Transmitter is dirty	Clean transmitter
Parameter value is #####	None	Measured value is out of range	Check measuring range and measuring units
Flashing bell in display 	WS11	The measured turbidity value is above the transmitter output setting	Change turbidity upper range in "Basic settings", see fig. 29, p. 21
	WS12	The measured suspended solids value is above the transmitter output setting	Change suspended solids upper range in "Basic settings", see fig. 29, p. 21
	WS13	The measured turbidity value is below the transmitter output setting	Change turbidity lower range in "Basic settings", see fig. 29, p. 21
	WS14	The measured suspended solids value is below the transmitter output setting	Change suspended solids lower range in "Basic settings", see fig. 29, p. 21
	WS15	Calibration point is too high	Calibrate at a lower concentration
	WS16	Calibration point is too low	Calibrate at a higher concentration

Symptom	Event code	Cause	Remedy
Flashing bell in display 	ES50	Calibration error	Perform calibration, see p. 26
	ES51	Calibration error	Perform calibration, see p. 26
	ES52	Calibration error	1. Perform calibration, see p. 26 2. Check units and range, see p. 21
	ES53	Error in EEPROM	Replace transmitter
	ES54	Software error	Replace transmitter

Troubleshooting guide - USC

Symptom	Current output	Event code	Cause	Remedy
None	Undefined	IU00	Power on	Registration of time of power on
		IU01	Add-on module applied	Registration of applied add-on module
		IU02	Add-on module defective or removed	Replace or install add-on module
		IU03	Parameter successfully corrected	Information
Empty display			1. Supply voltage 2. USC 5000/6000/7000 defective	1. Check supply voltage 2. Replace USC 5000/6000/7000
Dots in upper line of display	(I out 1)	EU61	See EU61 p. 39	Same as EU61 p. 39
	(I out 2)	EU62	See EU62 p. 39	
	(I out 3)	EU63	See EU63 p. 39	
	(I out 4)	EU64	See EU64 p. 39	
Flashing bell in display 	Undefined	WU10	I out 1: Value at 4 mA >= Value at 20 mA	Check I out 1 setup
		WU11	I out 2: Value at 4 mA >= Value at 20 mA	Check I out 2 setup
		WU12	I out 3: Value at 4 mA >= Value at 20 mA	Check I out 3 setup
		WU13	I out 4: Value at 4 mA >= Value at 20 mA	Check I out 4 setup
		WU14	The measured value has exceeded the current output 1 setting	Change value at 20 mA on I out 1
		WU15	The measured value has exceeded the current output 2 setting	Change value at 20 mA on I out 2
		WU16	The measured value has exceeded the current output 3 setting	Change value at 20 mA on I out 3
		WU17	The measured value has exceeded the current output 4 setting	Change value at 20 mA on I out 4
		WU18	The measured value is below the current output 1 setting	Change value at 4 mA on I out 1
		WU19	The measured value is below the current output 2 setting	Change value at 4 mA on I out 2
		WU20	The measured value is below the current output 3 setting	Change value at 4 mA on I out 3
WU21	The measured value is below the current output 4 setting	Change value at 4 mA on I out 4		

Symptom	Current output	Event code	Cause	Remedy
Flashing bell in display 	Undefined	WU39	HART communication error	Check cables
		WU40	TMS communication error	Replace TMS
		WU41	A parameter is out of range. It could not be replaced by its default value	Fixed at power-up
		WU43	Too many errors at the same time. Some errors are not registered correctly	Power-up USC
		WU49	Internal error	Power-up USC
	One or more current outputs = 3.8 mA or 24 mA	EU60	CAN bus application does not respond. This error is shown when the maximum number of communication attempts is exceeded.	<ol style="list-style-type: none"> 1. Power-up USC 2. Replace USC
	Undefined	EU61	USC unable to read data required for I OUT 1 <ol style="list-style-type: none"> 1. No reply from transmitter 2. Transmitter has got new address 3. Another master conflicts on HART® comm. 	<ol style="list-style-type: none"> 1. Check shielding and cable connections 2. Power-up USC 3. Disconnect the other master or set USC to another master, see fig. 44, p. 44 4. Check supply voltage at transmitter, supply voltage must be at least 20 V 5. Check shielding and cable connections 6. Replace transmitter 7. Replace USC
			<ol style="list-style-type: none"> 4. Supply voltage for transmitter too low 	
			<ol style="list-style-type: none"> 5. Too much noise on current loop 6. Transmitter defective 7. USC defective 	
			<ol style="list-style-type: none"> 1 - 7: Same as EU61 	
	EU62	USC unable to read data required for I OUT 2 <ol style="list-style-type: none"> 1 - 7: Same as EU61 	Same as EU61	
	EU63	USC unable to read data required for I OUT 3 <ol style="list-style-type: none"> 1 - 7: Same as EU61 	Same as EU61	
EU64	USC unable to read data required for I OUT 4 <ol style="list-style-type: none"> 1 - 7: Same as EU61 	Same as EU61		

Symptom	Current output	Event code	Cause	Remedy
Flashing bell in display 	Undefined	EU65	USC unable to read data required for relay 1 1 - 7: Same as EU61	Same as EU61
		EU66	USC unable to read data required for relay 2 1 - 7: Same as EU61	Same as EU61
		EU67	USC unable to read data required for relay 3 1 - 7: Same as EU61	Same as EU61
		EU68	USC unable to read data required for relay 4 1 - 7: Same as EU61	Same as EU61
		EU69	USC unable to read data required for relay 5 1 - 7: Same as EU61	Same as EU61

Technical Data

Transmitter

Measurement principle	Six channel multi-beam pulse infrared light principle with modified absorption measurement and 6 channel multi-angle measurement
Transmitter cable	Four-wire, shielded cable 4 x 0.34 mm ² (22 AWG), length 5 m (16.4')
Power supply	15-30 V d.c.; without wiper: 60 mA; with wiper: 85 mA (30 sec.)
Transmitter output	Digital HART® communication / RS485
Measuring range (can be conrysured)	Turbidity: 0.001 to 10000 FNU Suspended solids: 0.001 to 400 g/l
Sensitivity	Turbidity: 0 to 0.999 FNU: 0.001 FNU 1 to 9.99 FNU: 0.01 FNU 10 to 99.9 FNU: 0.1 FNU > 100 FNU: 1 FNU
	Suspended solids: 0 to 0.999 g/l: 0.001 g/l 1 to 9.99 g/l: 0.01 g/l 10 to 99.9 g/l: 0.1 g/l > 100 g/l: 1 g/l
Measuring uncertainty	Turbidity: Typically less than 3 % of actual concentration
	Suspended solids: Typically less than 5 % of actual concentration (depends on quality of calibration and media)
Response time	1 sec.
Enclosure	IP 68 to IEC 529 (10 m) / 10 bar pipe mounted; NEMA 6P (3')
Enclosure material	Stainless steel, Sapphire glass lenses
Dimensions and weight	Diameter: 40 mm (1.6") Length: 262 mm (10.3") + connection Weight: 1.1 to 1.3 kg (2.4 to 2.9 lbs)
Cleaning	Optional mechanical wiper controlled by transmitter

The worn TSS 4100 transmitter must be disposed as metallic waste.

USC

Type	USC 5000	USC 6000	USC 7000
No. of transmitters	1 (point-to-point installation)	1 (point-to-point installation)	15 (multidrop)
Current outputs	One 4-20 mA (scaleable), 24V active galvanic isolated Max. load: 800 ohm	Two 4-20 mA (scaleable), 24V active galvanic isolated Max. load: 800 ohm	Four 4-20 mA (scaleable), 24V active galvanic isolated Max. load: 800 ohm
Relay outputs	None	3 relay outputs SPST (max. 48 V a.c. or 30 Vrms 4 A)	5 relay outputs SPST (max. 48 V a.c. or 30 Vrms 4 A)
Digital input	Min. 12 to max 30 V d.c. (6 KOhm)	Min. 12 to max 30 V d.c. (6 KOhm)	Min. 12 to max 30 V d.c. (6 KOhm)
Display	Back-lit alphanumeric LCD display	Back-lit alphanumeric LCD display	Back-lit alphanumeric LCD display
Enclosure	IP 67 according to IEC 529; NEMA 4X	IP 67, IP 20 according to IEC 529; NEMA 4X	IP 67, IP 20 according to IEC 529; NEMA 4X
Ambient temperature	Storage: -40°C to +70°C (-40°F to 158°F) Operation: -40°C to +60°C (-40°F to 140°F)	Storage: -40°C to +70°C (-40°F to 158°F) Operation: -40°C to +60°C (-40°F to 140°F)	Storage: -40°C to +70°C (-40°F to 158°F) Operation: -40°C to +50°C (-40°F to 122°F)
Environment	Indoor use, altitude up to 2000 m Pollution Degree II Relative humidity 80% up to 31°C (87.8°F) decreasing linearly to 50% at 40°C (104°F)	Indoor use, altitude up to 2000 m Pollution Degree II Relative humidity 80% up to 31°C (87.8°F) decreasing linearly to 50% at 40°C (104°F)	Indoor use, altitude up to 2000 m Pollution Degree II Relative humidity 80% up to 31°C (87.8°F) decreasing linearly to 50% at 40°C (104°F)
Power supply	100-240 V a.c. +10%/-15% 50/60 Hz. 5-20VA Fuse: T500mA/250V (Not to be changed by user)	100-240 V a.c. +10%/-15% 50/60 Hz. 5-20VA Fuse: T500mA/250V (Not to be changed by user)	100-240 V a.c. +10%/-15% 50/60 Hz. 5-20VA Fuse: T500mA/250V (Not to be changed by user)
Cable glands	Jacob GmbH, cat. no. 50.013 PA (PG13.5) 6-12 mm cable diameter (UL approved: 9-12 mm)	Jacob GmbH, cat. no. 50.013 PA (PG13.5) 6-12 mm cable diameter (UL approved: 9-12 mm)	Jacob GmbH, cat. no. 50.013 PA (PG13.5) 6-12 mm cable diameter (UL approved: 9-12 mm)
Blind plugs	Jacob GmbH, cat. no. 1013 PA	Jacob GmbH, cat. no. 1013 PA	Jacob GmbH, cat. no. 1013 PA
Approvals	CE, C-tick and UL approved Emission: EN 50081 Immunity: EN 50082	CE, C-tick and UL approved Emission: EN 50081 Immunity: EN 50082	CE, C-tick and UL approved Emission: EN 50081 Immunity: EN 50082

The insulation between mains supply and all input and output terminals of the USC signal converter were provided with double or reinforced insulation by a dielectric strength voltage of 2300 V a.c. Installation category II.

Disposal in accordance with EU directive 2002/96/EC

In compliance with EU directive 2002/96/EC, HACH LANGE / the local subsidiary will accept back and dispose of the old instrument at no cost.



ATTENTION!

It is not allowed to dispose of the instrument using municipal waste disposal services. Please talk to your local HACH LANGE contact.

Important: Before returning goods to HACH LANGE, the products must be cleaned properly.

HART®

The TSS 4100 offers additional features which can be accessed through the USC 5000/6000/7000 signal converter or HART® communication. To use HART® communication it is necessary to use a PC or PLC with a HART® modem and associated software.

All *Universal Commands* are fully implemented, as are the necessary *Common Practice Commands*, but to ensure complete utilisation of the transmitter, special *Device Specific Commands* are used.

HART® communication makes it possible to read off:

- suspended solids
- turbidity
- alarms

When calibrating the EVITA® TSS transmitter the following can be performed with HART® communication:

- memorising the calibration points
- keying in of the calibration values determined by drying and weighing the samples

The following programming is possible with HART® communication:

- setting of measuring range
- setting of wiper interval

The USC 5000/6000/7000 can act as either a primary master or a secondary master. This can be set as shown in fig. 44.

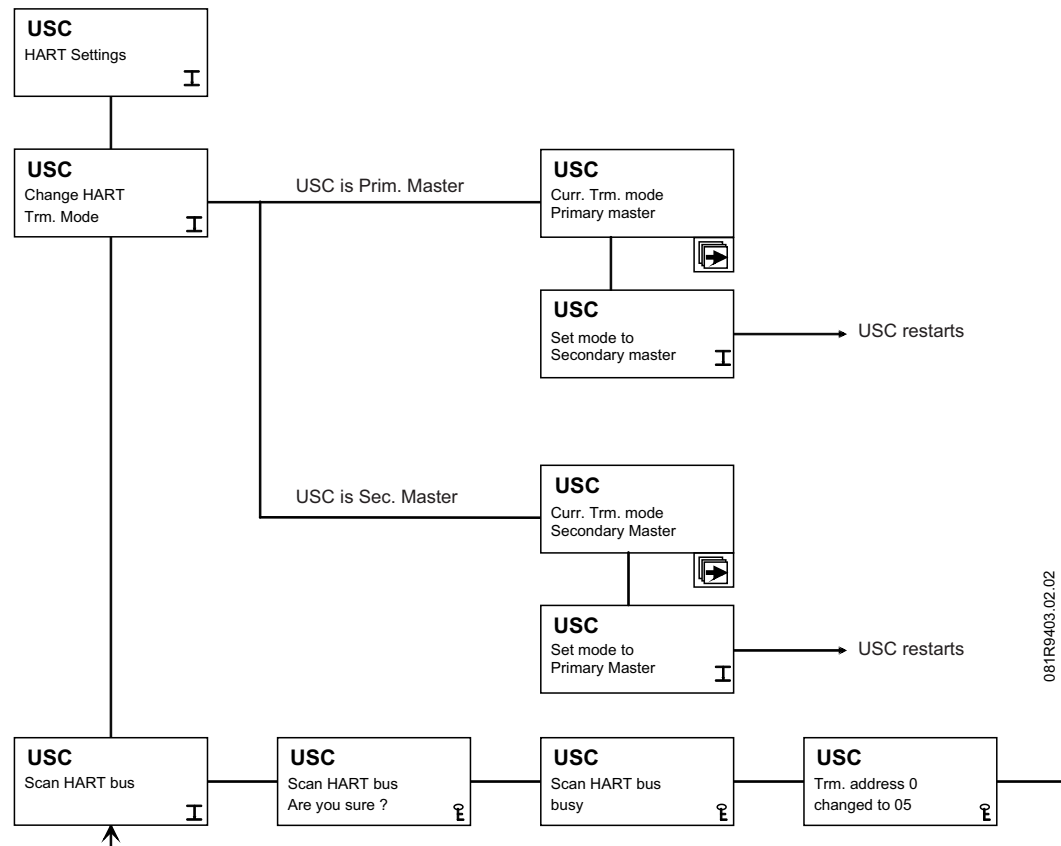

081R9403.02.02

Fig. 44

Warranty, liability and complaints

HACH LANGE GmbH warrants that the product supplied is free of material and manufacturing defects and undertakes the obligation to repair or replace any defective parts at zero cost (no guarantee of quality or durability).

At variance with our general terms and conditions, the warranty period for the EVITA series instruments is 12 months.

EVITA INSITU/ EVITA INLINE: On the conclusion of a system care contract within 6 months of purchase, the warranty period is extended based on the terms in the system care contract. HACH LANGE GmbH offers various system care contracts with different services and warranty period extensions.

With the exclusion of the further claims, the supplier is liable for defects including the lack of assured properties as follows: all those parts that, within the warranty period calculated from the day of the transfer of risk, can be demonstrated to have become unusable or that can only be used with significant limitations due to a situation present prior to the transfer of risk, in particular due to incorrect design, poor materials or inadequate finish will be improved or replaced, at the supplier's discretion. The identification of such defects must be notified to the supplier in writing without delay, however at the latest 14 days after the identification of the fault. If the customer fails to notify the supplier, the product is considered approved despite the defect. Further liability for any direct or indirect damages is not accepted.

If instrument-specific maintenance and servicing work defined by the supplier is to be performed within the warranty period by the customer (maintenance) or by the supplier (servicing) and these requirements are not met, claims for damages due to the failure to comply with the requirements are rendered void.

HACH LANGE is not responsible for any indirect or consequential damages, e.g. injuries or damage to property, failure in operation, including loss of production, loss of profits, loss of goods in stock or similar that could result from defects and/or delayed delivery of products sold, irrespective of the cause including faulty manufacture, design and materials.

Furthermore, the warranty does not include:

- Wearing parts and consumables
- If the product is damaged because it was not operated/maintained in accordance with the manual
- If the product is damaged due to incorrect installation or operation
- Damage caused by electrical failure or lightning/ overvoltage
- Defects resulting from failure to clean prior to storage
- Defects due to use outside the specifications for the transmitter

The following points are to be undertaken (even without a system care contract) by the customer:

- Attention! EVITA INSITU 4100 / EVITA INSITU 2100 / EVITA INLINE 4150:
 - o The transmitter is to be cleaned with a cleaning cartridge prior to every chemical change
- Documentation of the cleaning and maintenance work performed
- The replacement of a transmitter supplied
- The cleaning, packaging and organisation of the return of the faulty transmitter to HACH LANGE for repair and/or troubleshooting

HACH LANGE GmbH process instruments are of proven reliability in many applications and are therefore often used in automatic control loops to provide the most economical possible operation of the related process.

To avoid or limit consequential damage, it is therefore recommended to design the control loop such that a malfunction in an instrument results in an automatic change over to the backup control system; this is the safest operating state for the environment and the process.

If not otherwise agreed, the general terms and conditions of HACH LANGE GmbH also apply

Contacts

Please find below the extract of HACH LANGE companies. Other company locations:
www.hach-lange.com

HACH LANGE GmbH
Willstätterstraße 11
D-40549 Düsseldorf
Tel. +49 (0) 211- 52 88 - 0
Fax +49 (0) 211- 52 88 - 143
info@hach-lange.de
www.hach-lange.de

HACH LANGE LTD
Pacific Way
Salford
Manchester, M50 1DL
Tel. +44 (0)161 8 72 14 87
Fax +44 (0)161 8 48 73 24
info@hach-lange.co.uk
www.hach-lange.co.uk

HACH LANGE
HACH SAS
33, Rue du Ballon
F-93165 Noisy Le Grand
Tél. +33 (0)1 48 15 8080
Fax +33 (0)1 48 15 80 00
info@hach-lange.fr
www.hach-lange.fr

DR. BRUNO LANGE
GES. MBH
Industriestraße 12
A-3200 Obergrafendorf
Tel. +43 (0) 2747 - 74 12
Fax +43 (0) 2747 - 42 18
info@hach-lange.at
www.hach-lange.de

DR. BRUNO LANGE AG
Juchstrasse 1
CH-8604 Hegnau
Tel. +41 (0)44- 9 45 66 10
Fax +41 (0)44- 9 45 66 76
info@hach-lange.ch
www.hach-lange.ch

HACH LANGE SA
Motstraat 54
B-2800 Mechelen
Tél. +32 (0)15 42 35 00
Fax +32 (0)15 41 61 20
info@hach-lange.be
www.hach-lange.be

DR. LANGE NEDERLAND B.V.
Laan van Westroijen 2a
NL-4003 AZ Tiel
Tel. +31(0)3 44 63 11 30
Fax +31(0)3 44 63 11 50
info@hach-lange.nl
www.hach-lange.nl

HACH LANGE AB
Vinhundsvägen159A
S-128 62 Sköndal
Tel. +46 (0)8 7 98 05 00
Fax +46 (0)8 7 98 05 30
info@hach-lange.se
www.hach-lange.se

HACH LANGE A/S
Åkandevej 21
DK-2700 Brønshøj
Tel. +45 36 77 29 11
Fax +45 36 77 49 11
info@hach-lange.dk
www.hach-lange.dk

HACH LANGE S.L.U.
C/Araba 45, Apdo. 220
E-20800 Zarautz/Guipúzcoa
Tel. +34 9 43 89 43 79
Fax +34 9 43 13 02 41
info@hach-lange.es
www.hach-lange.es

HACH LANGE SP.ZO.O.
ul. Opolska 143 a
PL-52-013 Wroclaw
Tel. +48 71 3 42 10-81
Fax +48 71 3 42 10-79
info@hach-lange.pl
www.hach-lange.pl

HACH LANGE S.R.L.
Via Riccione, 14
I-20156 Milano
Tel. +39 02 39 23 14-1
Fax +39 02 39 23 14-39
info@hach-lange.it
www.hach-lange.it

HACH LANGE S.R.O.
Lešanská 2a/1176
CZ-141 00 Praha 4
Tel. +420 272 12 45 45
Fax +420 272 12 45 46
info@hach-lange.cz
www.hach-lange.cz

HACH LANGE S.R.O.
Sabinovská 10
SK-821 02 Bratislava
Tel. +421 2 4820 9091
Fax +421 2 4820 9093
info@hach-lange.sk
www.hach-lange.com

HACH LANGE LDA
Rua dos Malhões,
Edif. D. Pedro I
P-2770-071 Paço D'Arcos
Tel. +351 210 00 1750
Fax +351 210 00 8140
info@hach-lange.pt
www.hach-lange.pt

